

USER MANUAL

PM2

CUSTOM  M[®]

CUSTOM S.p.A.
Via Berettine 2/B
43010 Fontevivo (PARMA) - Italy
Tel. : +39 0521-680111
Fax : +39 0521-610701
http: www.custom.biz

Customer Service Department:
www.custom4u.it

© 2024 CUSTOM S.p.A. – Italy.
All rights reserved. Total or partial reproduction of this manual in whatever form, whether by printed or electronic means, is forbidden. While guaranteeing that the information contained in it has been carefully checked, CUSTOM S.p.A. and other entities utilized in the realization of this manual bear no responsibility for how the manual is used. Information regarding any errors found in it or suggestions on how it could be improved are appreciated. Since products are subject to continuous check and improvement, CUSTOM S.p.A. reserves the right to make changes in information contained in this manual without prior notification.

The pre-installed multimedia contents are protected from Copyright CUSTOM S.p.A. Other company and product names mentioned herein may be trademarks of their respective companies. Mention of third-party products is for informational purposes only and constitutes neither an endorsement nor a recommendation. CUSTOM S.p.A. assumes no responsibility with regard to the performance or use of these products.

THE IMAGES USED IN THIS MANUAL ARE USED AS AN ILLUSTRATIVE EXAMPLES. THEY COULDN'T REPRODUCE THE DESCRIBED MODEL FAITHFULLY.

UNLESS OTHERWISE SPECIFIED, THE INFORMATION GIVEN IN THIS MANUAL ARE REFERRED TO ALL MODELS IN PRODUCTION AT THE ISSUE DATE OF THIS DOCUMENT.

GENERAL INSTRUCTIONS

CUSTOM S.p.A. declines all responsibility for accidents or damage to persons or property occurring as a result of tampering, structural or functional modifications, unsuitable or incorrect installations, environments not in keeping with the equipment's protection degree or with the required temperature and humidity conditions, failure to carry out maintenance and periodical inspections and poor repair work.

GENERAL SAFETY INFORMATION

Your attention is drawn to the following actions that could compromise the characteristics of the product:

- Read and retain the instructions which follow.
- Follow all indications and instructions given on the device.
- Make sure that the surface on which the device rests is stable. If it is not, the device could fall, seriously damaging it.
- Make sure that the device rests on a hard (non-padded) surface and that there is sufficient ventilation.
- Do not fix indissolubly the device or its accessories such as power supplies unless specifically provided in this manual.
- When positioning the device, make sure cables do not get damaged.
- [Only OEM equipment] The equipment must be installed in a kiosk or system that provides mechanical, electrical and fire protection.
- The mains power supply must comply with the rules in force in the Country where you intend to install the equipment.
- Make sure that there is an easily-accessible outlet with a capacity of no less than 10A closely to where the device is to be installed.
- Make sure the power cable provided with the appliance, or that you intend to use is suitable with the wall socket available in the system.
- Make sure the electrical system that supplies power to the device is equipped with a ground wire and is protected by a differential switch.
- Before any type of work is done on the machine, disconnect the power supply.
- Use the type of electrical power supply indicated on the device label.
- These devices are intended to be powered by a separately certified power module having an SELV, non-energy hazardous output. (IEC60950-1 second edition).
- [Only POS equipment] The energy to the equipment must be provided by power supply approved by CUSTOM S.p.A.
- Take care the operating temperature range of equipment and its ancillary components.
- Do not block the ventilation openings.
- Do not insert objects inside the device as this could cause short-circuiting or damage components that could jeopardize printer functioning.
- Do not carry out repairs on the device yourself, except for the normal maintenance operations given in the user manual.
- The equipment must be accessible on these components only to trained, authorized personnel.
- Periodically perform scheduled maintenance on the device to avoid dirt build-up that could compromise the correct, safe operation of the unit.
- Do not touch the head heating line with bare hands or metal objects. Do not perform any operation inside the printer immediately after printing because the head and motor tend to become very hot.
- Use consumables approved by CUSTOM S.p.A.



THE CE MARK AFFIXED TO THE PRODUCT CERTIFY THAT THE PRODUCT SATISFIES THE BASIC SAFETY REQUIREMENTS.

The device is in conformity with the essential Electromagnetic Compatibility and Electric Safety requirements laid down in Directives 2014/30/EU and 2014/35/EU inasmuch as it was designed in conformity with the provisions laid down in the following Standards:

- EN 55032 (*Electromagnetic compatibility of multimedia equipment - Emission Requirements*)
- EN 55024/EN55035 (*Electromagnetic compatibility of multimedia equipment - Immunity requirements*)
- EN IEC/EN62368-1 (*Audio/video, information and communication technology equipment*)

The device is in conformity with the essential requirements laid down in Directives 2014/53/EU about devices equipped with intentional radiators. The Declaration of Conformity and other available certifications can be downloaded from the site www.custom4u.it.



GUIDELINES FOR THE DISPOSAL OF THE PRODUCT

The crossed-out rubbish bin logo means that used electrical and electronic products shall NOT be mixed with unsorted municipal waste. For more detailed information about recycling of this product, refer to the instructions of your country for the disposal of these products.

- Do not dispose of this equipment as miscellaneous solid municipal waste, but arrange to have it collected separately.
- The re-use or correct recycling of the electronic and electrical equipment (EEE) is important in order to protect the environment and the wellbeing of humans.
- In accordance with European Directive WEEE 2012/19/EU, special collection points are available to which to deliver waste electrical and electronic equipment and the equipment can also be handed over to a distributor at the moment of purchasing a new equivalent type.
- The public administration and producers of electrical and electronic equipment are involved in facilitating the processes of the re-use and recovery of waste electrical and electronic equipment through the organisation of collection activities and the use of appropriate planning arrangements.
- Unauthorised disposal of waste electrical and electronic equipment is punishable by law with the appropriate penalties.
- For the waste sorting of the packaging materials, please check the local waste disposal laws.



The format used for this manual improves use of natural resources reducing the quantity of necessary paper to print this copy.



FCC STATEMENT
(FEDERAL COMMUNICATIONS
COMMISSIONS).

This note is valid only for device bringing FCC trademark.

This device complies with Part 15 of the FCC Rules. Operation is subject to the following conditions:

The devices may not cause harmful interference.
The devices must accept any interference received, including interference that may cause undesired operation.

NOTE: This equipment has been tested and found to comply with the limits for a Class B digital device, pursuant to Part 15 of the FCC Rules. These limits are designed to provide reasonable protection against harmful interference in a residential installation. This equipment generates, uses and can radiate radio frequency energy and, if not installed and used in accordance with the instructions, may cause harmful interference to radio communications. However, there is no guarantee that interference will not occur in a particular installation. If this equipment does cause harmful interference to radio or television reception, which can be determined by turning the equipment off and on, the user is encouraged to try and correct the interference by one or more of the following measures:

Reorient or relocate the receiving antenna.

Increase the separation between the equipment and receiver.

Connect the equipment into an outlet on a circuit different from that to which the receiver is connected.

Consult the dealer or an experienced radio/TV technician for help.

Modifications to this product not authorized by CUSTOM S.p.A. could void the FCC & Industry Canada regulations and negate your authority to operate the product.

This Class B digital apparatus complies with Canadian ICES-003.

Cet appareil numérique de la classe B est conforme à la norme NMB-003 du Canada.

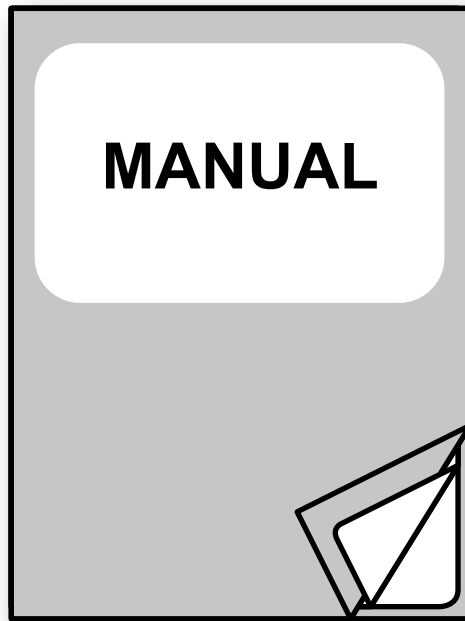

For details on the commands,
refer to the manual with code **0577200M000085**

For further information about the use of “PrinterSet” tool
refer to the manual with code **78200000001800**

TABLE OF CONTENTS

1	INTRODUCTION	9
2	DESCRIPTION	11
2.1	Box contents	11
2.2	Device components	12
2.3	Product label	13
2.4	Key functions: power up	14
2.5	Key functions: standby	15
2.6	Status messages	16
3	INSTALLATION	17
3.1	“EASYLOCK” fixing system	17
3.2	Fixing with screws	20
3.3	Upside down installation	22
3.4	Removing the anti-jam separator	23
3.5	Connections	24
3.6	Pinout	26
3.7	Service cable	28
3.8	Serial port setting	29
3.9	Driver and SDK	31
4	OPERATION	33
4.1	Opening cover for paper compartment	33
4.2	Switch the device on	34
4.3	Loading the paper roll	36
5	CONFIGURATION	39
5.1	Configuration by software	39
5.2	Configuration by keys	41
5.3	Device status	43
5.4	Communication parameters	44
5.5	Operating parameters	45
5.6	Alignment parameters	48
5.7	Hexadecimal dump	49

6	ALIGNMENT	51
6.1	Enable alignment	52
6.2	Alignment parameters	54
6.3	Printing area	56
7	MAINTENANCE	57
7.1	Paper jam	57
7.2	Planning of cleaning operations	58
7.3	Cleaning	59
7.4	Firmware upgrade	62
8	SPECIFICATIONS	65
8.1	Hardware specifications	65
8.2	Character specifications	68
8.3	Device dimensions	69
8.4	Device dimensions with extended range module	70
8.5	Device dimensions with grey frame 112x112	71
8.6	Power supply dimensions	72
8.7	Paper specification	73
8.8	Character sets	76
9	CONSUMABLES	79
10	ACCESSORIES	81
11	TECHNICAL SERVICE	83



1 INTRODUCTION

This document is divided into sections and chapters. Each chapter can be reached by the index at the beginning of this document. The index can be reached by the button on each page as shown in the diagram below.

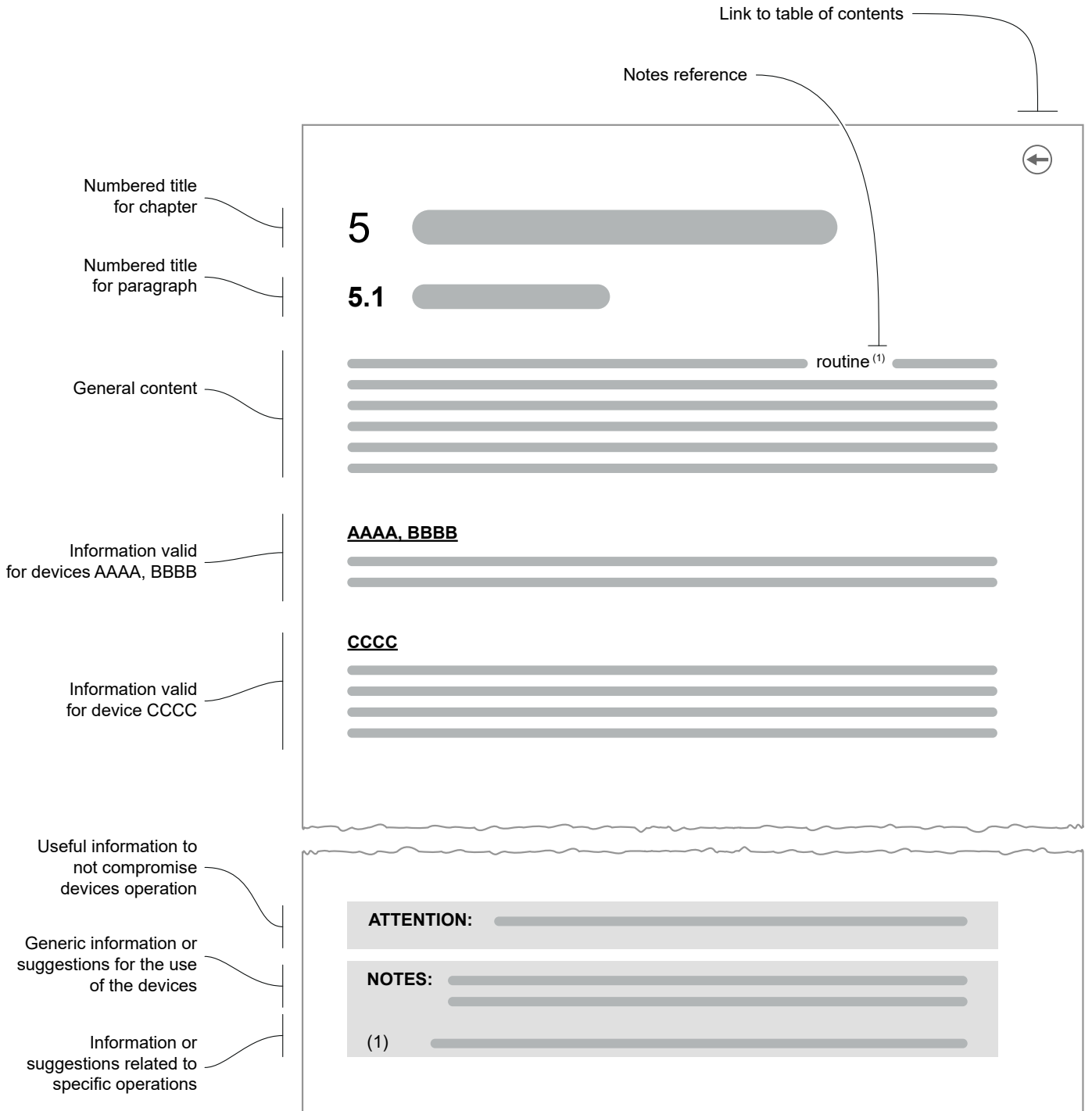



2 DESCRIPTION

2.1 Box contents

Remove the device from its carton being careful not to damage the packing material so that it may be re-used if the device is to be transported in the future.

Make sure that all the components illustrated below are present and that there are no signs of damage. If there are, contact customer service.

1. Fixing clips (x 2)
2. Device
3. Documentation (installation instruction sheet)

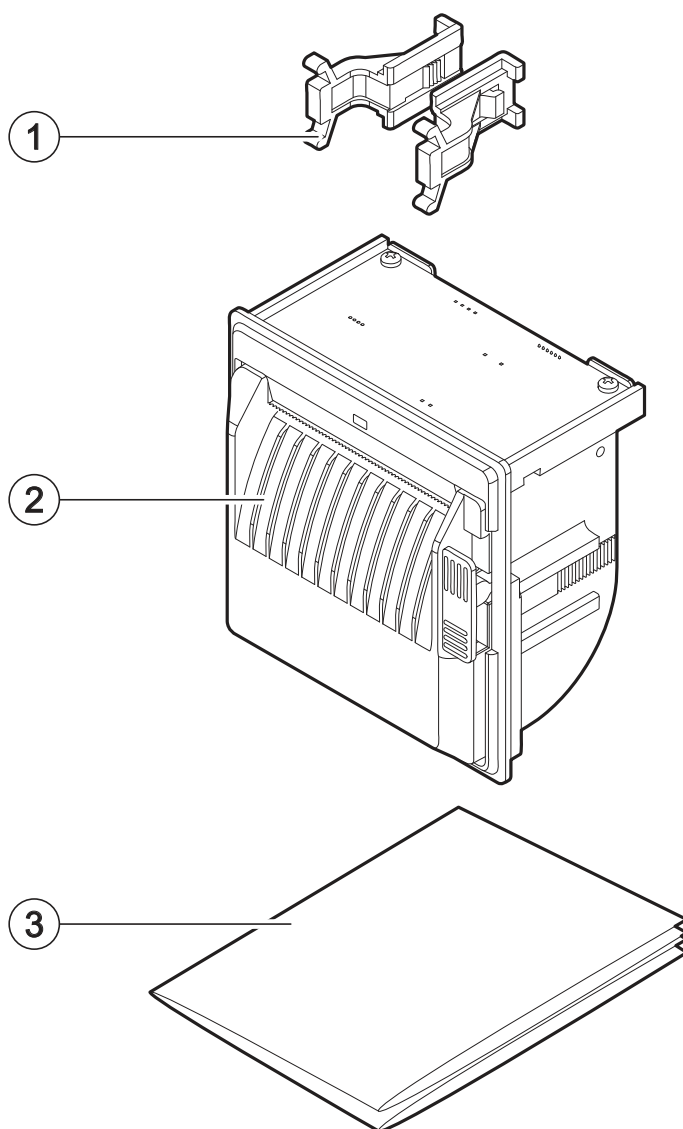

2.2 Device components

1. Connector for optional module for extended range from 8 Vdc to 42 Vdc (see [chapter 10](#))
2. Power supply port
3. USB port
4. RS232/TTL serial port
5. Opening lever for paper compartment cover
6. Paper presence and black mark alignment sensor
7. Status LED
8. Paper out with serrated blade
9. Paper compartment cover
10. Switch for RS232/TTL serial communication

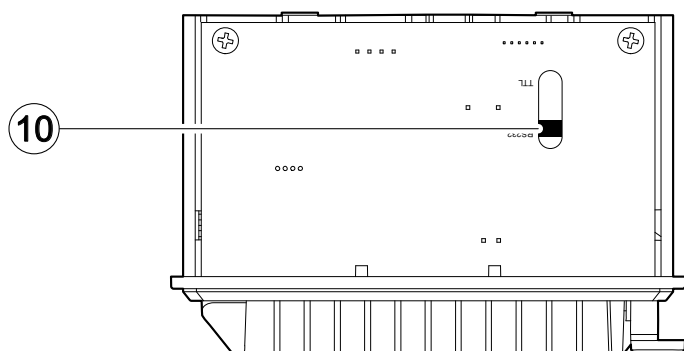
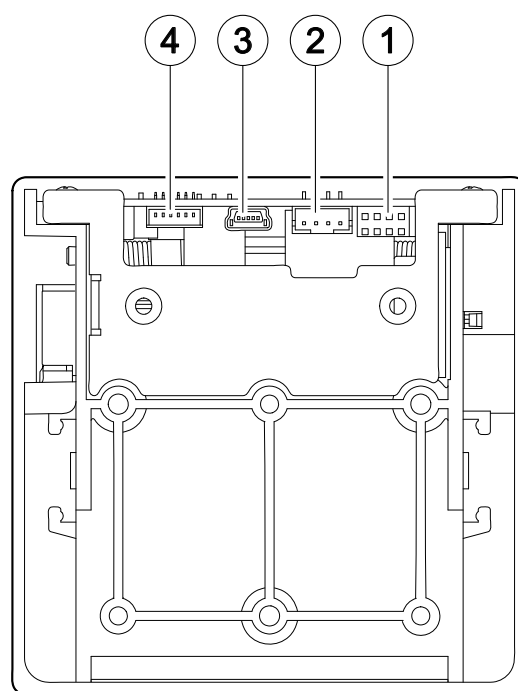
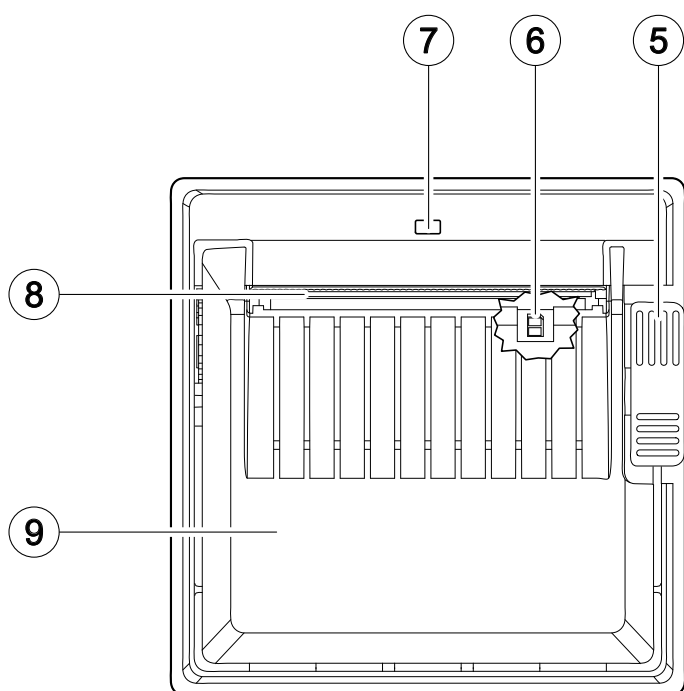



2.3 Product label

The main data used to identify the machine are shown on the label attached to the bottom of the device. In particular, it shows the electrical data for the connection to a power source. It also shows the product code, the serial number and the hardware revision (R).

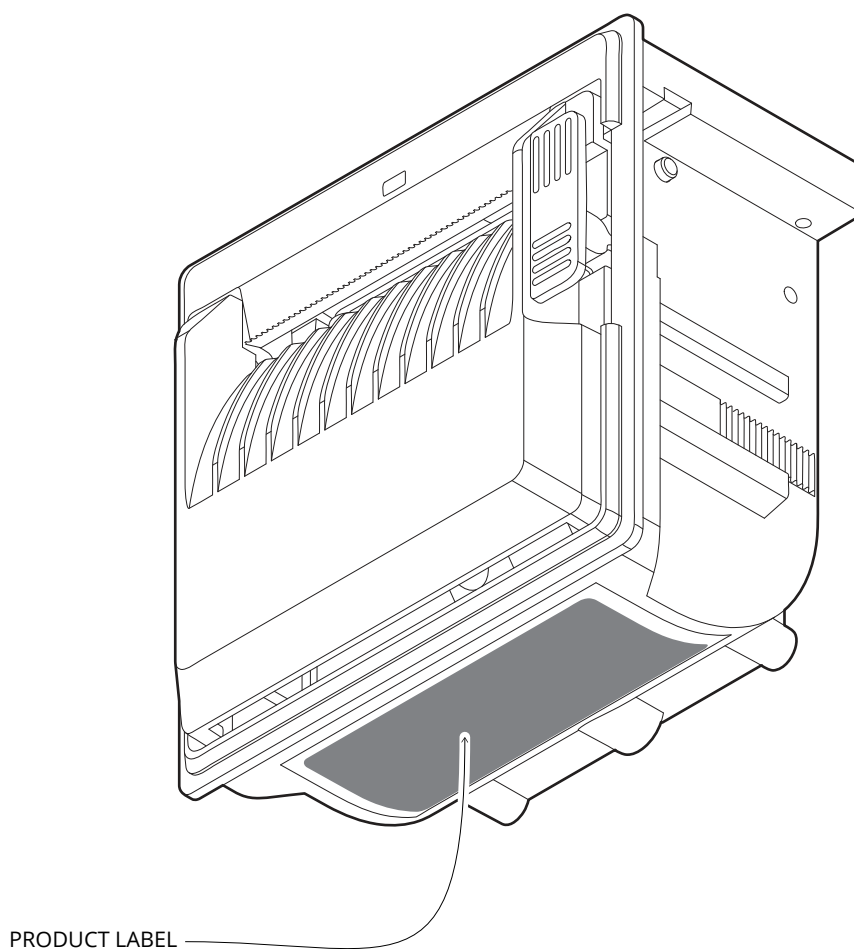
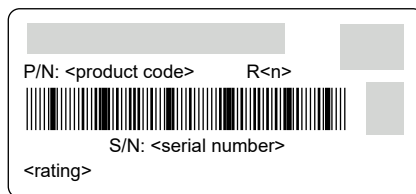

2.4 Key functions: power up

The device is not provided with a service key.

To perform the following functions, you should build a service cable with a service key as described in to be connected to the serial port of the device.

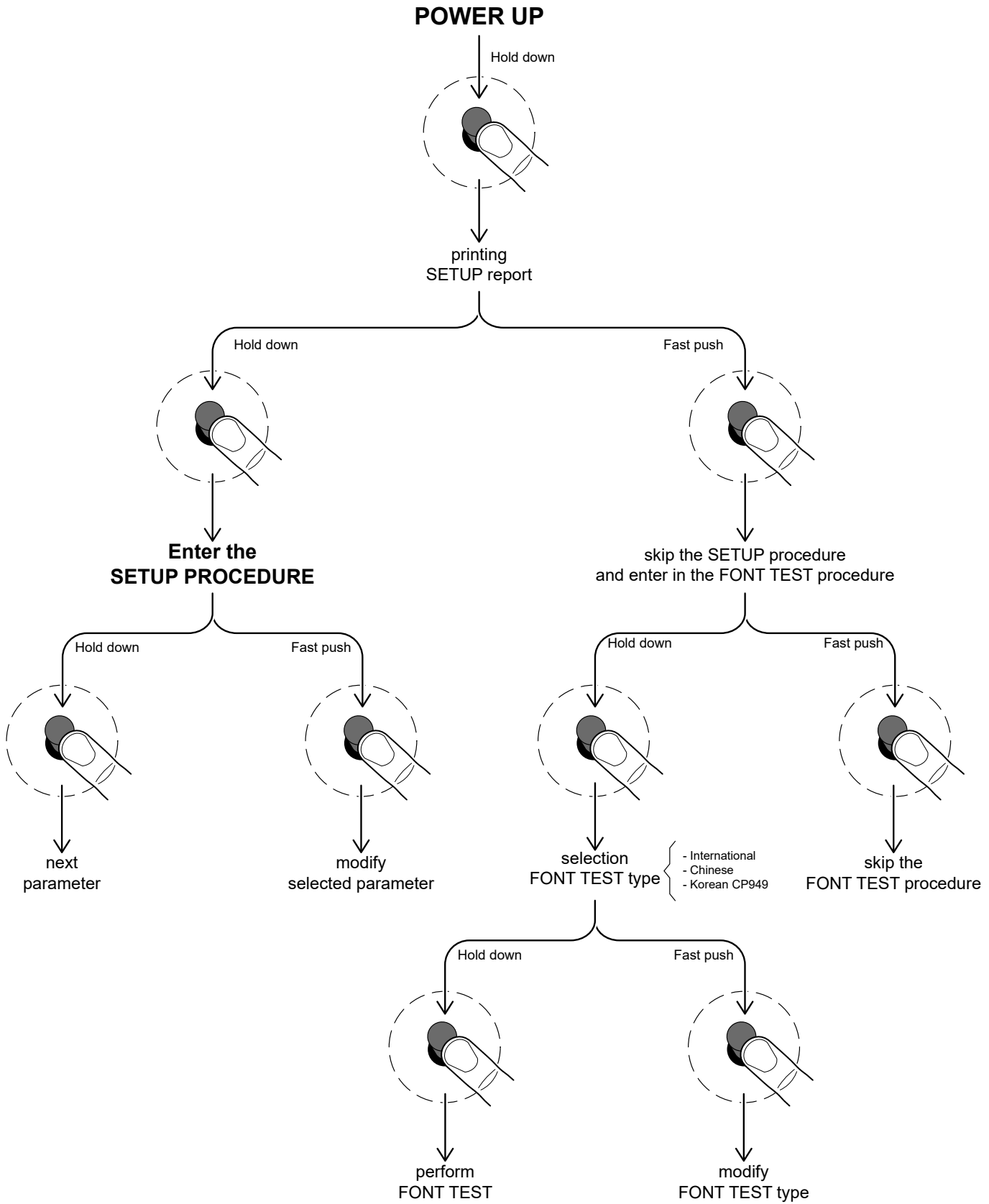

2.5 Key functions: standby

The device is not provided with a service key.

To perform the following functions, you should build a service cable with a service key as described in to be connected to the serial port of the device.

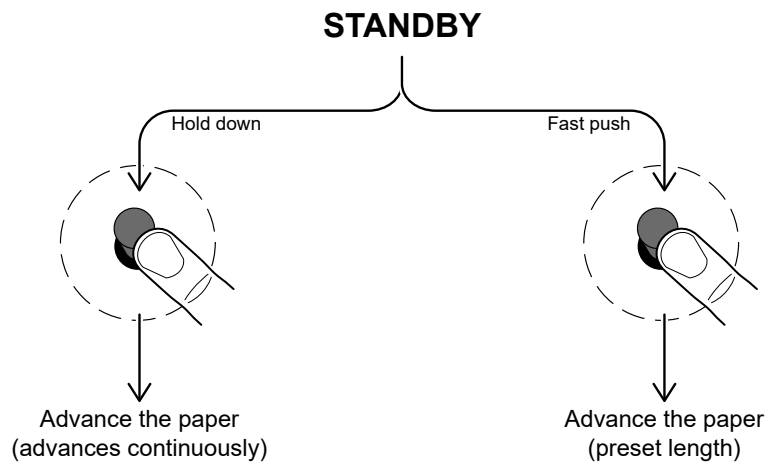



2.6 Status messages

The status LED indicates hardware status of device.

The default color of the status LED is blue but the user can change the color of the on and off states via commands (refer to the device command manual) or with the two setup parameters “LED bar FGND” and “LED bar BGND” (see [paragraph 5.5](#)).

Given in the table below are the various LED signals and the corresponding device status.

STATUS LED		DESCRIPTION
-	OFF	DEVICE OFF
BLUE	ON	DEVICE ON: NO ERROR
BLUE RECOVERABLE ERROR	x 2	PRINTHEAD OVERHEATED
	x 3	PAPER END
	x 4	POWER SUPPLY VOLTAGE INCORRECT
	x 5	RECEPTION ERRORS (PARITY, FRAME ERROR, OVERRUN ERROR)
	x 6	COMMAND NOT RECOGNIZED
	x 7	COMMAND RECEPTION TIME OUT

3 INSTALLATION

3.1 "EASYLOCK" fixing system

The device includes two plastic clips for fixing to the panel. This system allows you to lock the device on the panels of thickness max. 11 millimetres and requires no tools. Proceed as follows.
All the dimensions shown in following figures are in millimetres.

1

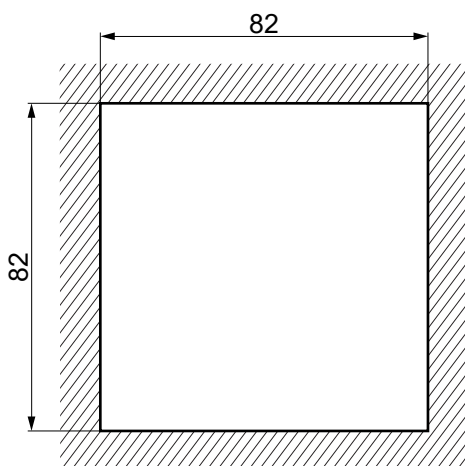

ATTENTION:
Prepare the hole in the panel correctly as shown in the figure in order to avoid deformation and torsion of the device which could compromise its operation.

Make a panel cutting for the device housing with the measurements shown in the figure.

2

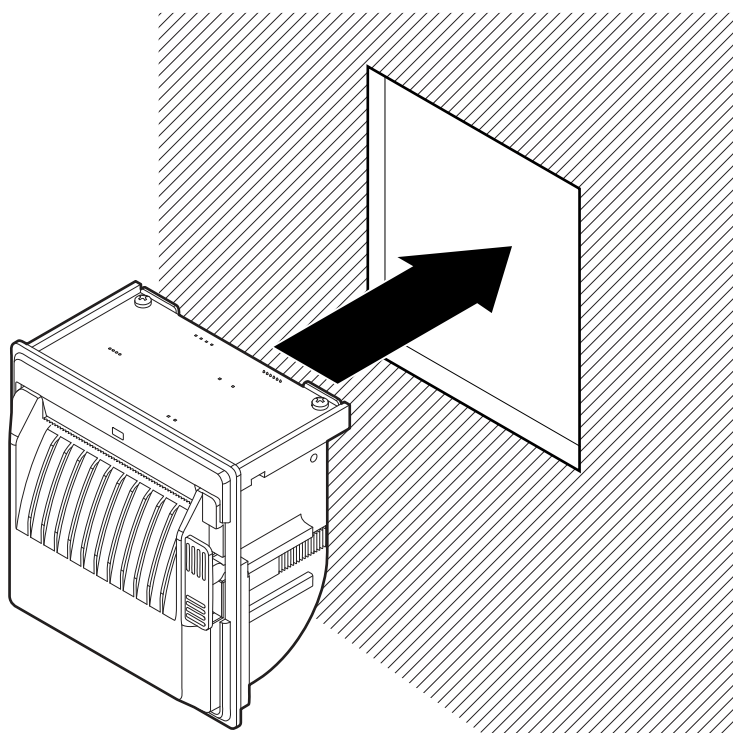

Insert the device inside the panel.



3

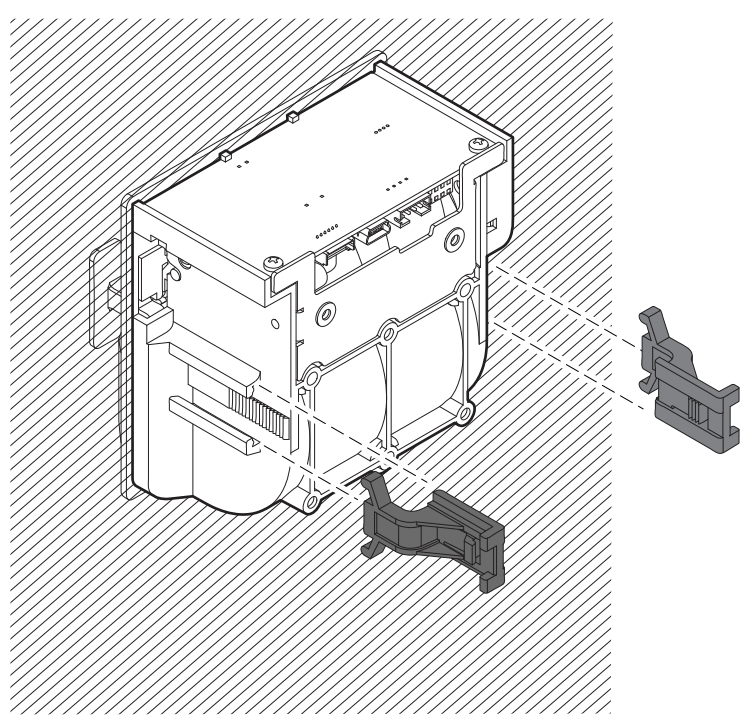

Insert the fixing clips into the seat on both the device sides.

4

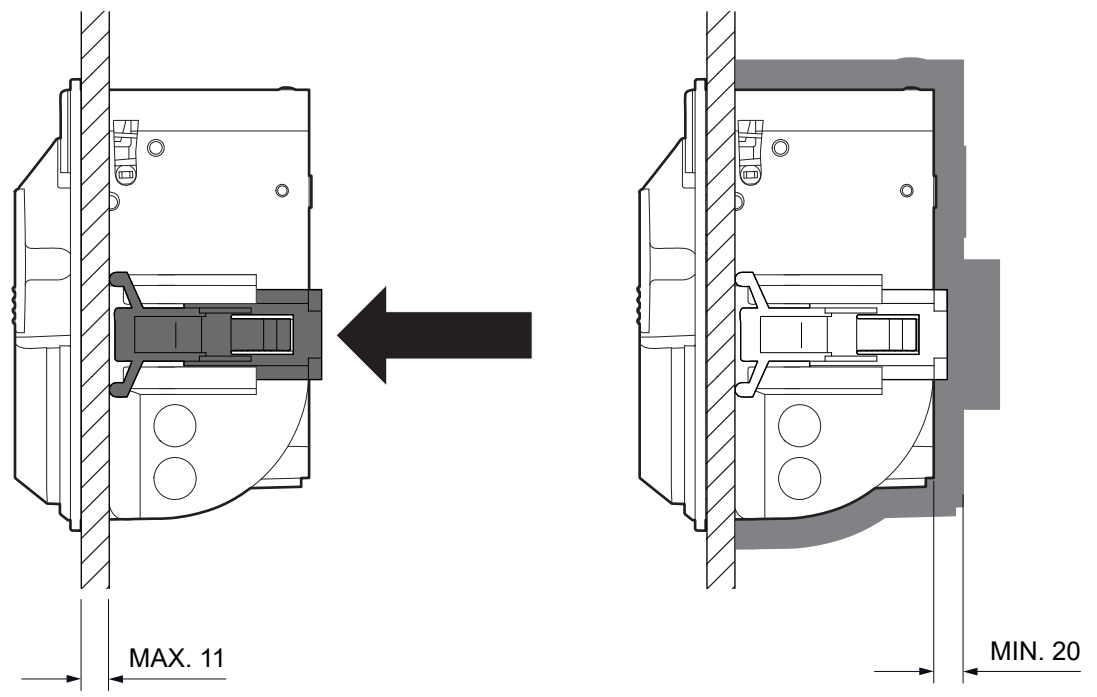

Push the two fixing hooks to strike the panel.
Make sure to leave adequate free space around the device of at least 20 millimeters.

5

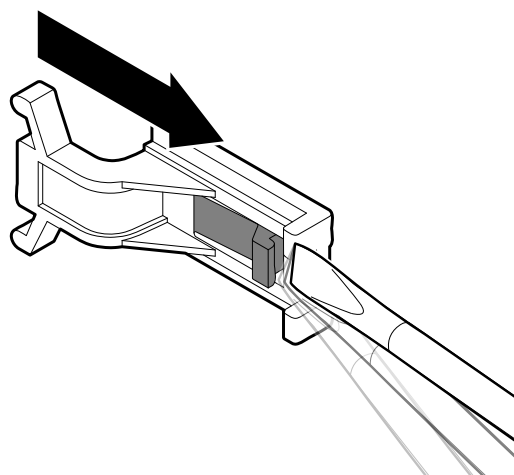

ATTENTION:
While using the screwdriver,
be carefull not to damage
the device components.

To remove the fixing hooks lift the lever shown in figure
with a small screwdriver.



3.2 Fixing with screws

The device can be secured to the panel with 3 screws (not supplied) to be tighten on the rear side of the device (SCHEME A) or from the paper compartment (SCHEME B).

All the dimensions shown in following figures are in millimetres.

SCHEME A

Fixing on the rear side

No.3 self-tapping screws for plastic d = 3

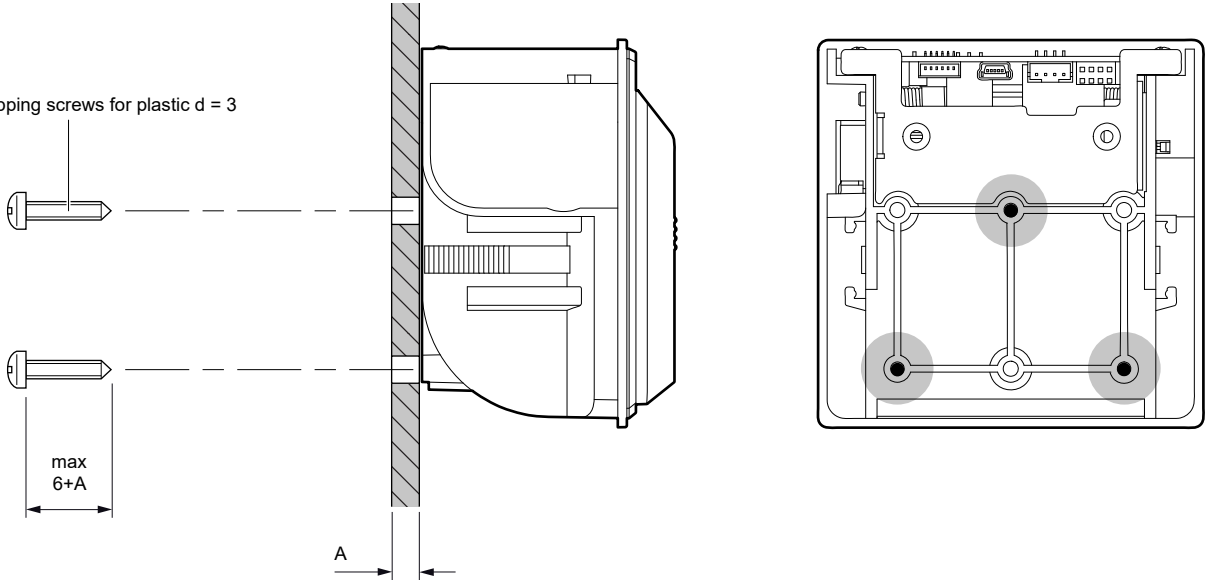

SCHEME B

Fixing from paper compartment

No.3 threaded nut

No.3 M3 screws

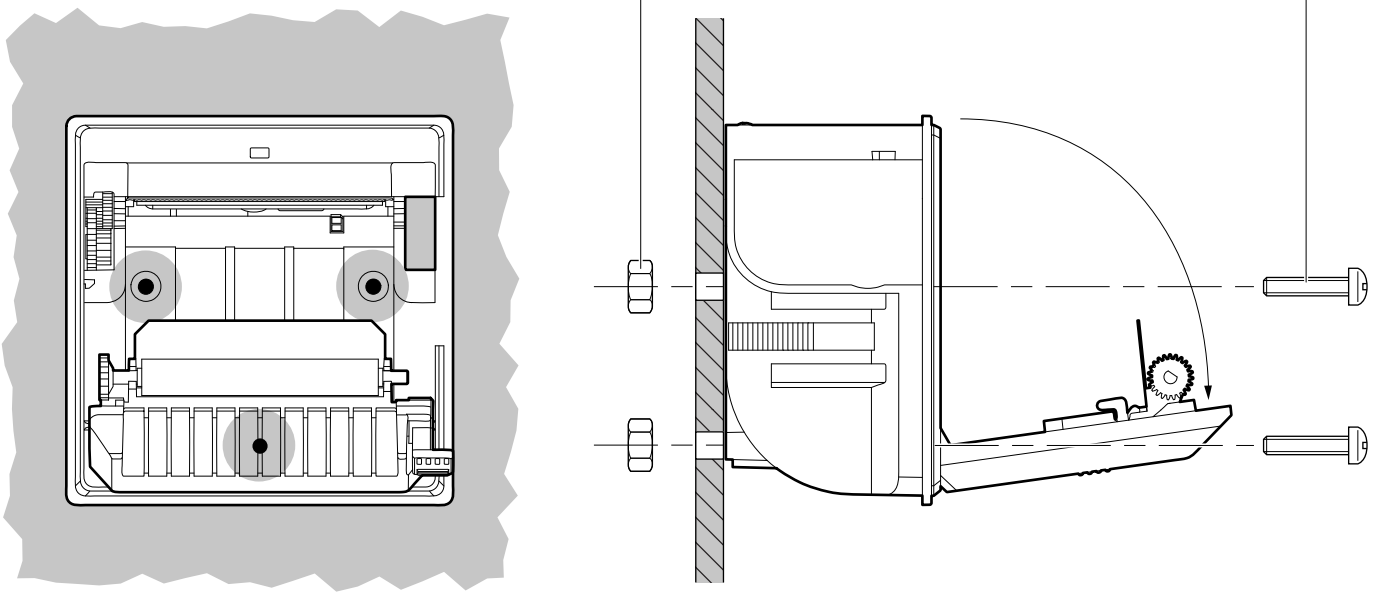



The panel must provide a drilling complies with the measures shown in the following figures.

Moreover, when you place the device in the operating position, make sure to leave the proper free space around the device of at least 20 millimeters, also considering the space for opening the cover so to not compromise operation and maintenance. Refer to [paragraph 8.3](#) for models dimensions.

Drilling for mounting on panel with

SCHEME A

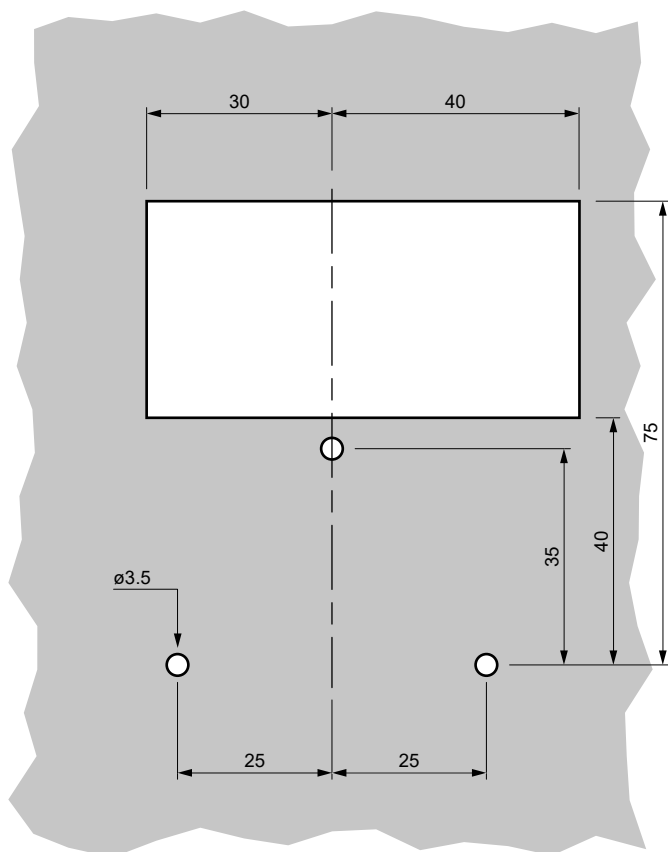

Drilling for mounting on panel with

SCHEME B

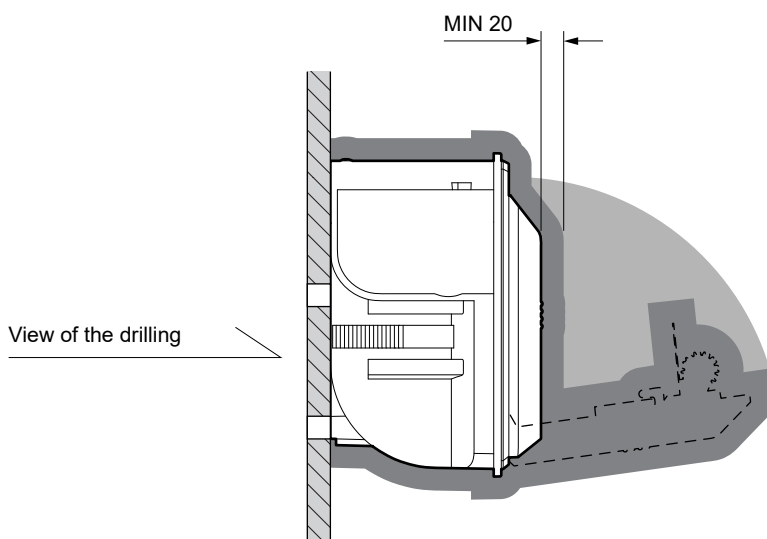
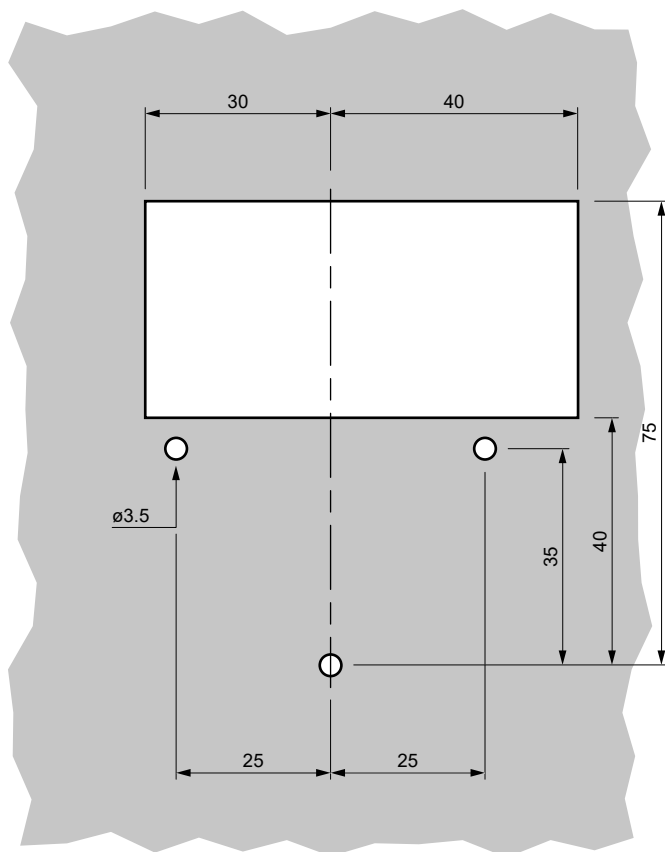

ATTENTION: Correctly prepare the fixing holes for screws and the drilling for the paper mouth in order to avoid deformation and torsion of the device or its components which could compromise its operation.

3.3 Upside down installation

The device can be installed in upside down position. In case of fixing with screws, the drilling pattern of the panel shown in [paragraph 3.2](#) must be inverted

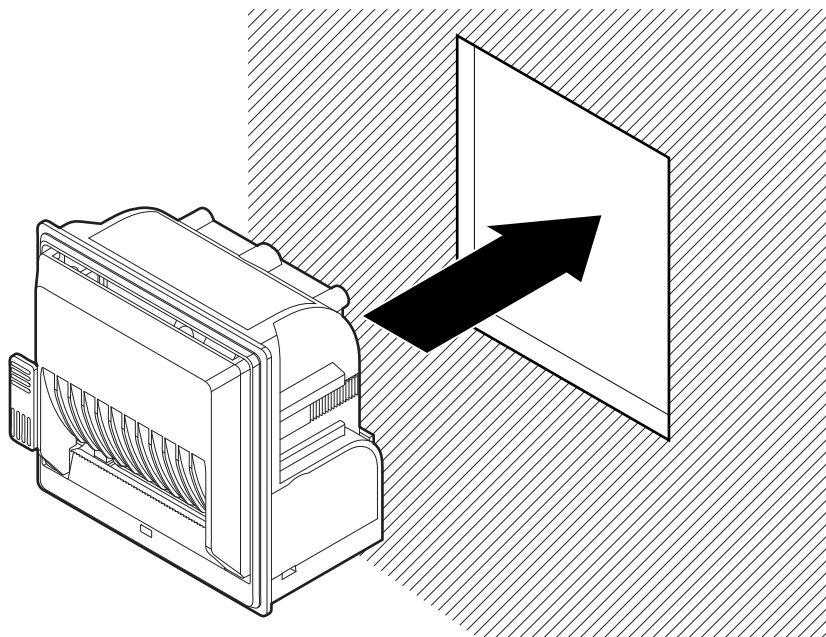

When the device is installed in the upside down position, pay attention when opening the paper compartment cover (see [paragraph 4.1](#)) to prevent the paper roll from falling and unrolling.

Operation in the upside down position is guaranteed by the anti-jam separator located under the platen roller and by the anti-friction pad on the opening lever.

If the anti-jam separator is removed for use with linerless paper (see [paragraph 3.4](#)), the device cannot be installed in the upside down position.

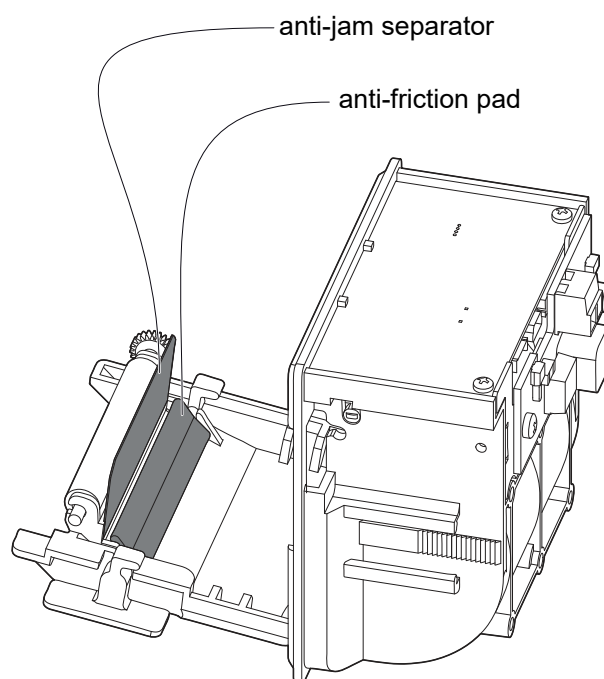

3.4 Removing the anti-jam separator

For using the device with the linerless paper (see [paragraph 3.4](#)), the anti-jam separator located under the platen roller must be removed for use with linerless paper by the following procedure.

ATTENTION: The removal operation is irreversible and once the separator has been removed, the device can no longer be installed in an upside down position (see [paragraph 3.3](#)).

1

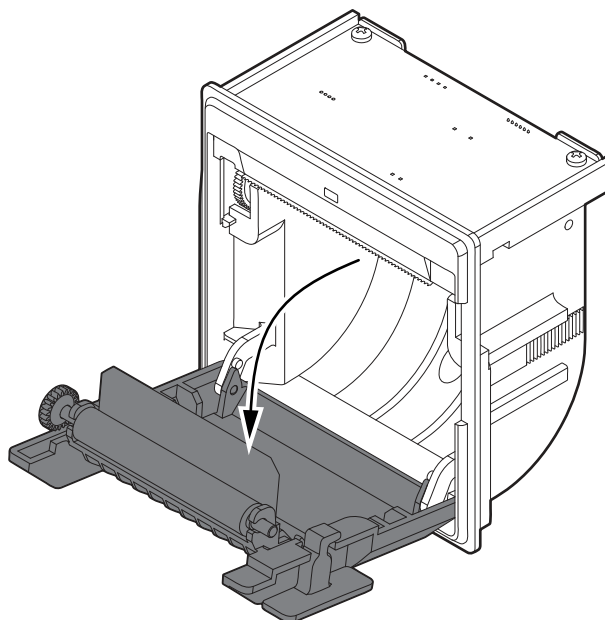

Open the cover of the paper compartment completely (see [paragraph 4.1](#)).

2

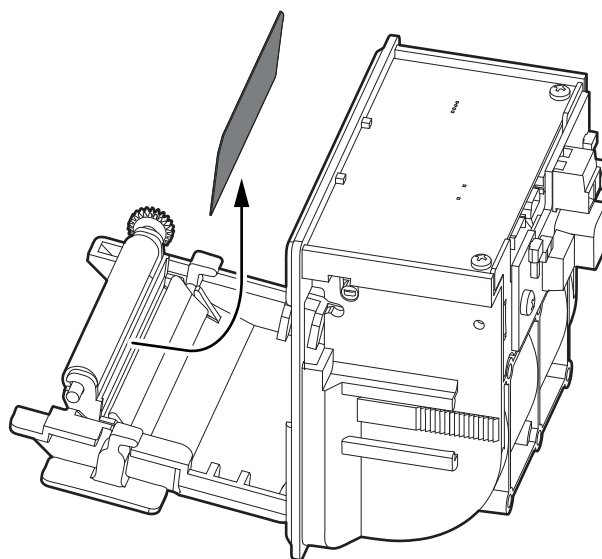

Remove the anti-jam separator by detaching it from the cover.



3.5 Connections

The following figure shows the possible connections for the device. When the RS232 and USB communication cables are connected to the device at the same time, communication takes place via the USB port.

PM2

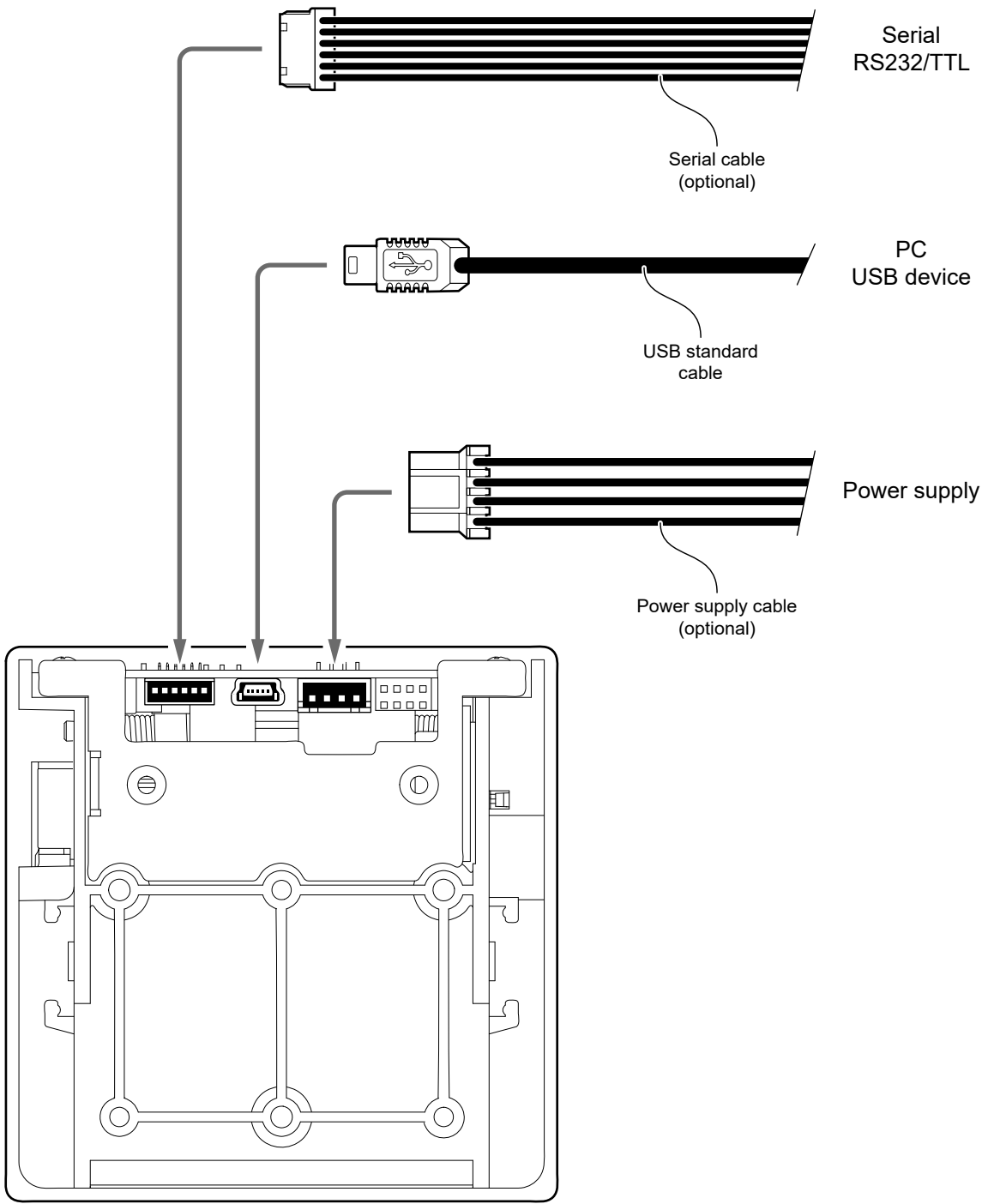

ATTENTION: In some conditions, we recommend the installation of a ferrite core on the power supply cable.



PM2 with optional module for extended range

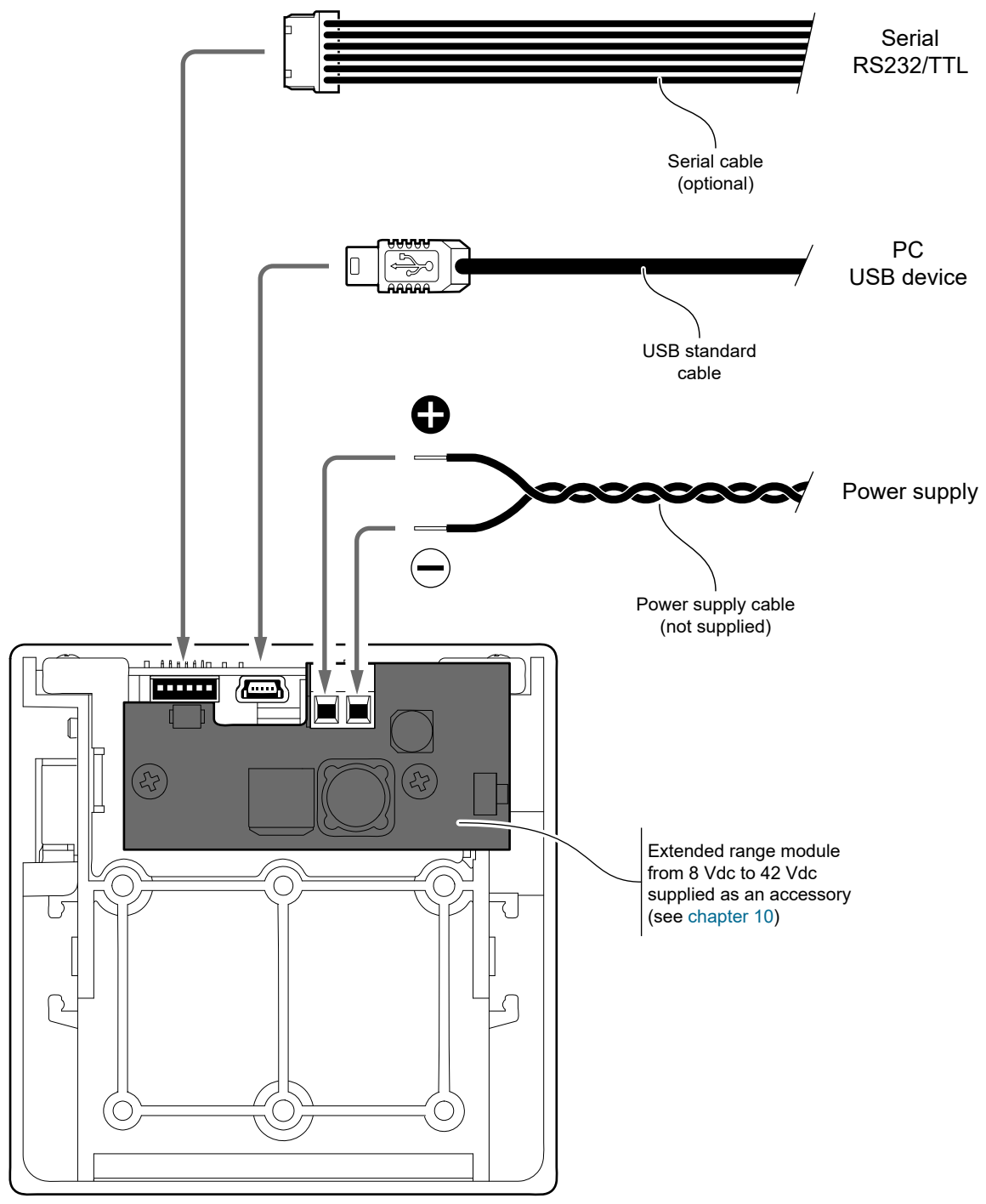

ATTENTION: In some conditions, we recommend the installation of a ferrite core on the power supply cable.



3.6 Pinout

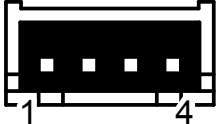

POWER SUPPLY
JST male connector (S4B-PH-K-S)



The following figure shows the connector pinout of the power supply cable for the device:

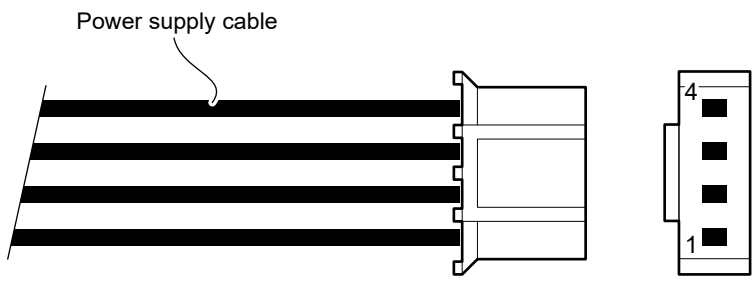

Female JST connector series PHR-4

PIN	Cable color	Signal
4	Black	GND
3	Black	GND
2	Orange	+VP
1	Red	+VCC

ATTENTION:
Respect power supply polarity.

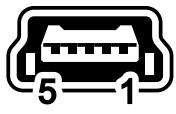

MINI USB INTERFACE
Female MINI USB type B connector

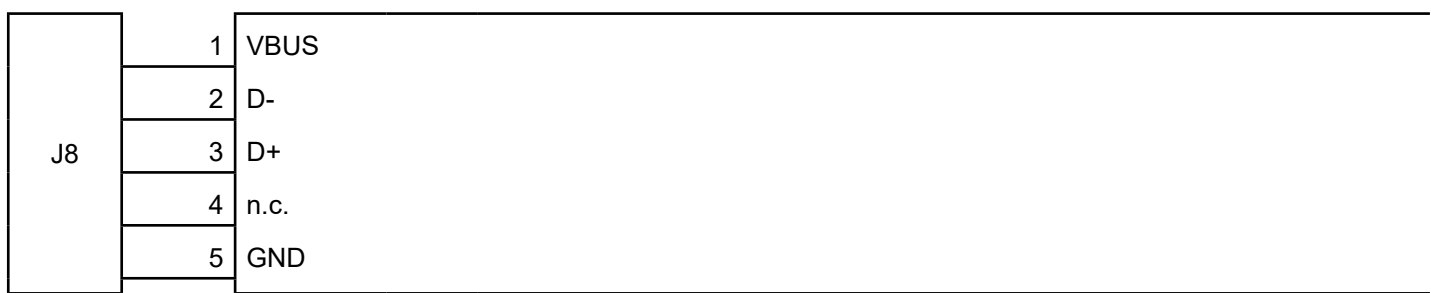



RS232/TTL SERIAL INTERFACE

Molex male connector 53048-0610 series (90°)

J3	1	RT	
	2	TX	During transmission, takes the values -VRS232 and + VRS232 depending on data
	3	RX	During reception, takes the values -VRS232 and +VRS232 depending on data
	4	GND	
	5	PUSH	
	6	LED	

Given the presence of the RS232 standard, logic value "0" corresponds to the voltage value +VRS232 (voltage value between +3Vdc and +15Vdc) and logic value "1" corresponds to the voltage value -VRS232 (voltage value between -3Vdc and -15Vdc).

When use a serial cable, we recommend the installation of a ferrite core on the power supply cable.

3.7 Service cable

To perform the service operations with the device, as the configuration by key (paragraph 5.2), you should build a cable such as the one shows in figure, that consists in the following components:

1. connector MOLEX 51021 female 6 pin for the connection to the serial port of the device
2. status LED for the messages described in paragraph 2.6
3. service key for the functions described in paragraph 2.4 and paragraph 2.5
4. DB9 connector for the connection to a personal computer

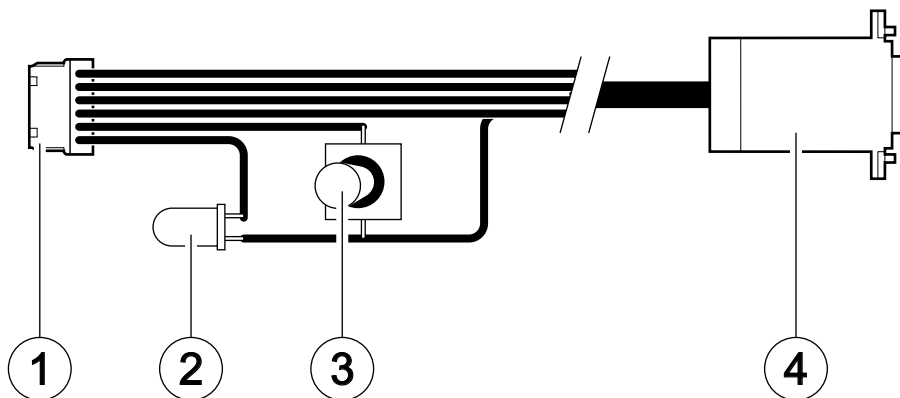

The following picture shows the wiring diagram to build the service cable.

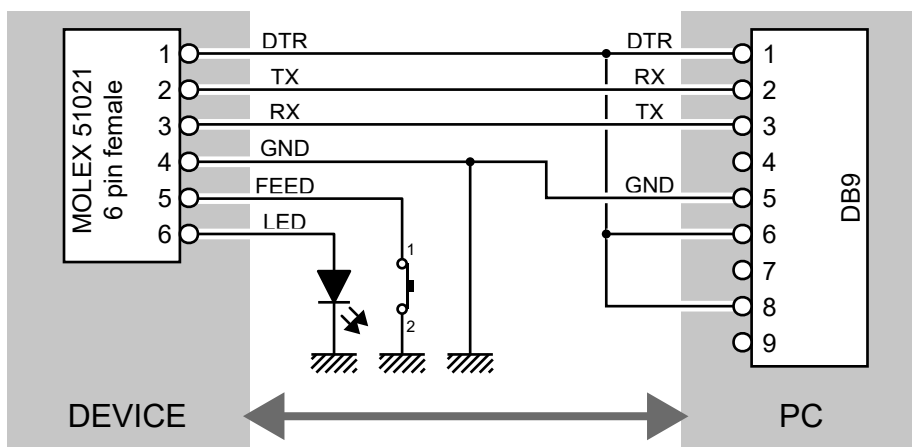

3.8 Serial port setting

To set the serial port of the device, slide the switch shown in figure in the correct position:

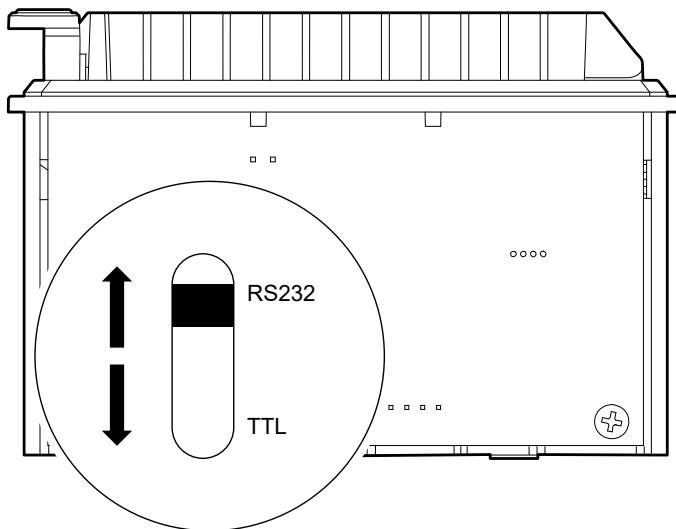

In the serial protocol, the signals which distinguish the communication are TD, RD, and RTS if the RTS/CTS protocol has been selected while, if the XON/XOFF protocol has been selected, the signals are TD and RD.

Transmission format



NOTES:

- (1) Bit 7 is present if only in the device set-up is enabled 8 bit/char as data length.
- (2) Parity Bit is preset if only in the device set-up the parity is enabled.

RTS/CTS Protocol

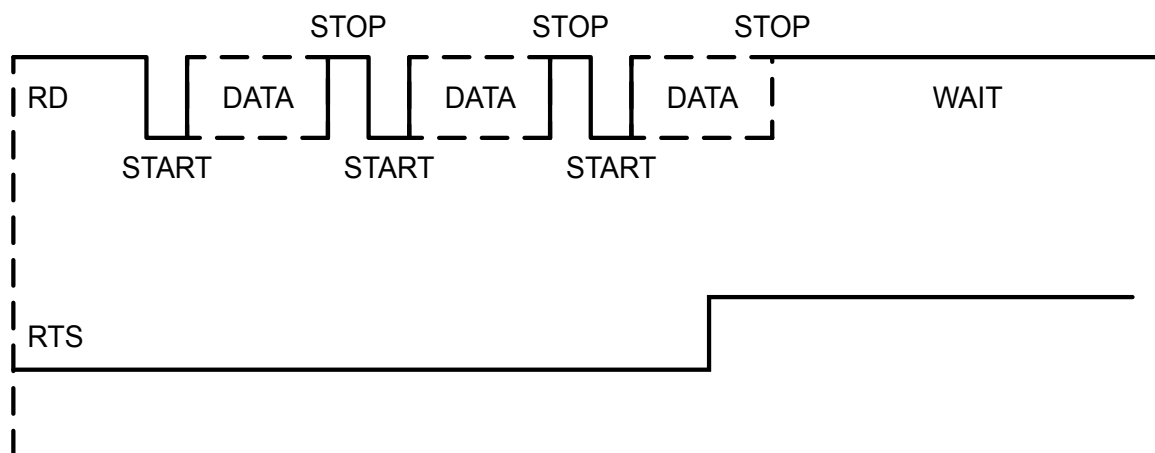



XON/XOFF protocol

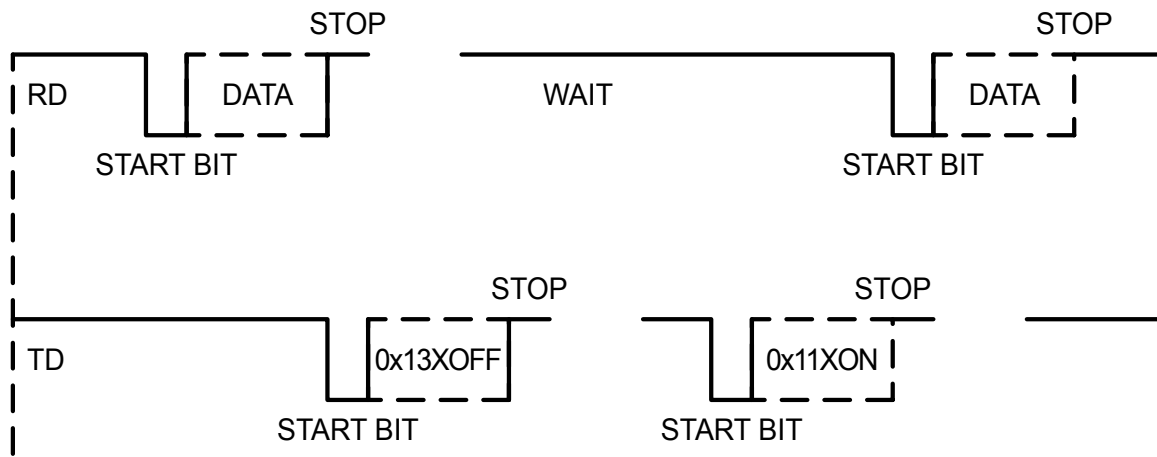



3.9 Driver and SDK

The drivers for the following operating system are available in the website www.custom4u.it:

OPERATING SYSTEM	DESCRIPTION	INSTALLATION PROCEDURE
Windows	Driver for Windows 7 (32/64 bit)	From the Start menu, press Run and type-in the path where the SW was saved on your PC, then click OK. Follow the instructions that appear on the screen to install the driver.
	Driver for Windows 10 (32/64 bit)	
	Driver for Windows 11 (64 bit)	
	OPOS SDK	Extract the zipped folder to the destination path desired. Follow the instructions present in the software package that you downloaded on how to install and use the SDK.
	JavaPOS SDK	
Windows API SDK		
Linux	Driver CUPS (32/64 bit)	Follow the instruction get back on the "Readme.txt" file. You can find it in the software package downloaded in advance.
	Driver for VIRTUAL COM (32/64 bit)	
	JavaPOS SDK	Extract the zipped folder to the destination path desired. Follow the instructions present in the software package that you downloaded on how to install and use the SDK.
Linux API SDK		
Android	ANDROID API SDK	



4 OPERATION

4.1 Opening cover for paper compartment

1

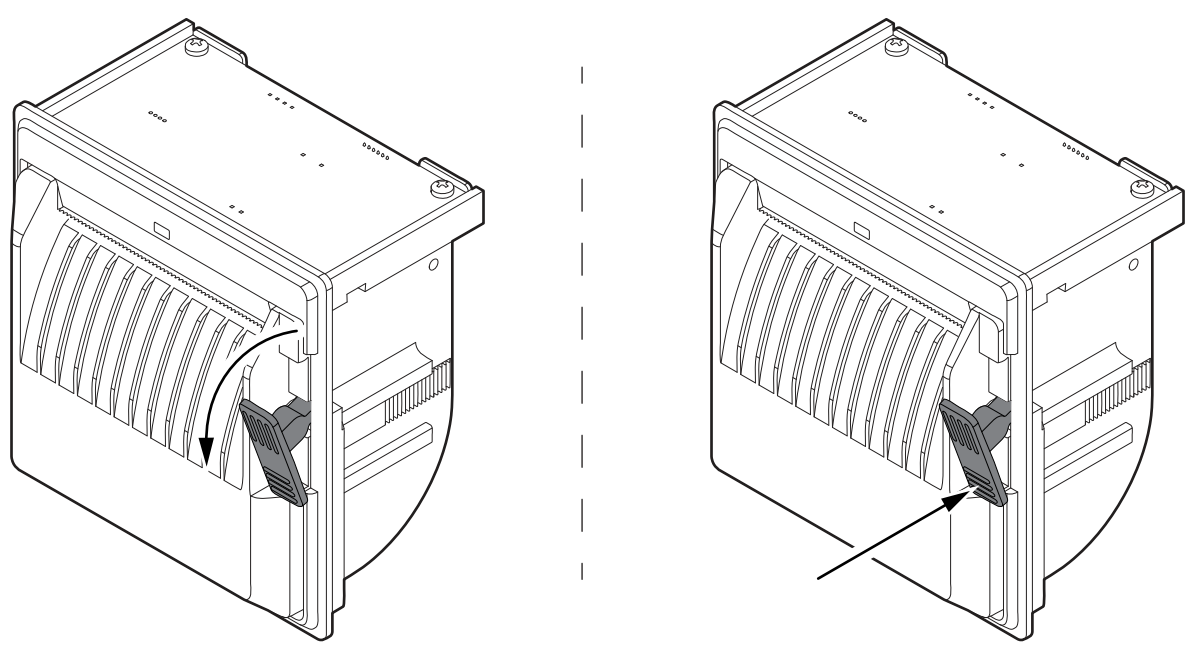

Wide the upper portion or push on the lower portion of the opening lever to unhook the cover of the paper compartment.

2

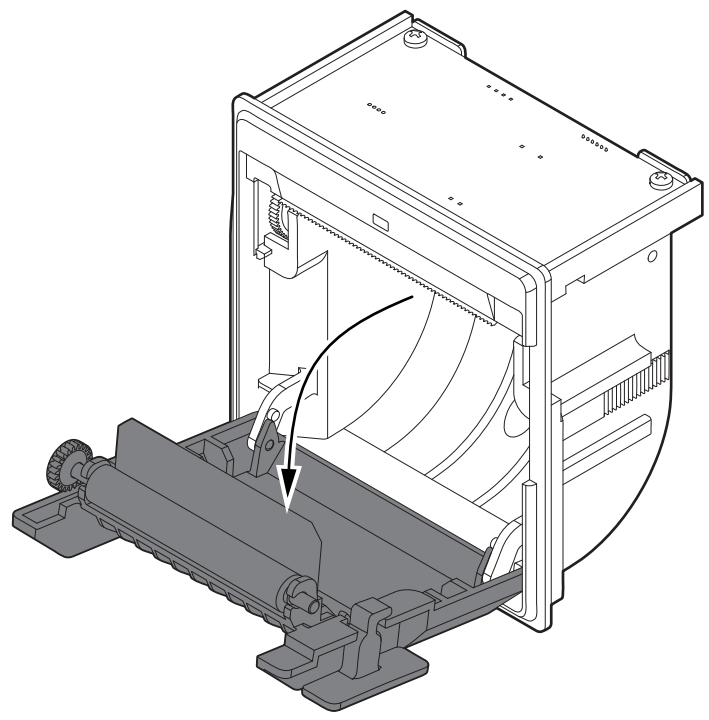

Open the cover of the paper compartment completely.

4.2 Switch the device on

PM2

1

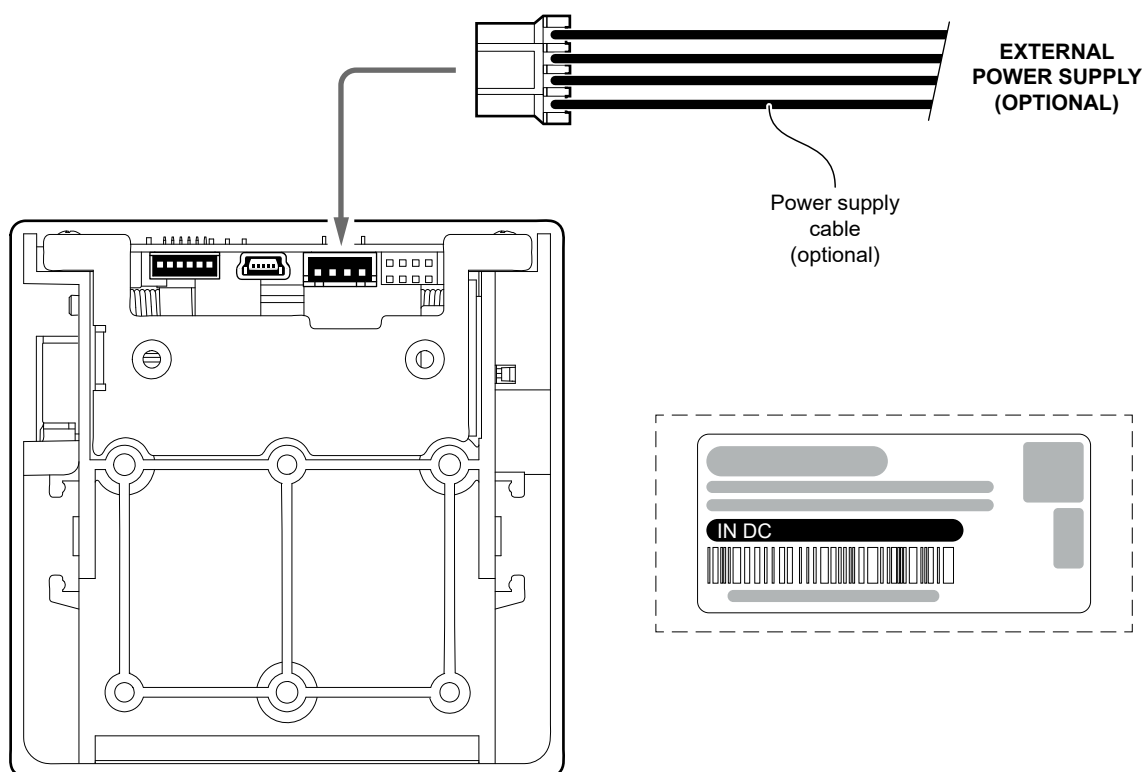

Connect the power supply cable to an external power supply unit and to the device.
Use the type of electrical power supply indicated on the label.

2

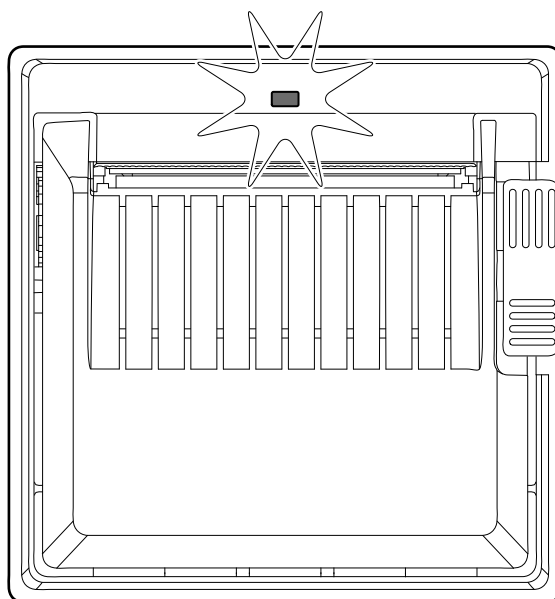

The blue status LED turns on.
The device is ready.

PM2 with optional module for extended range

1

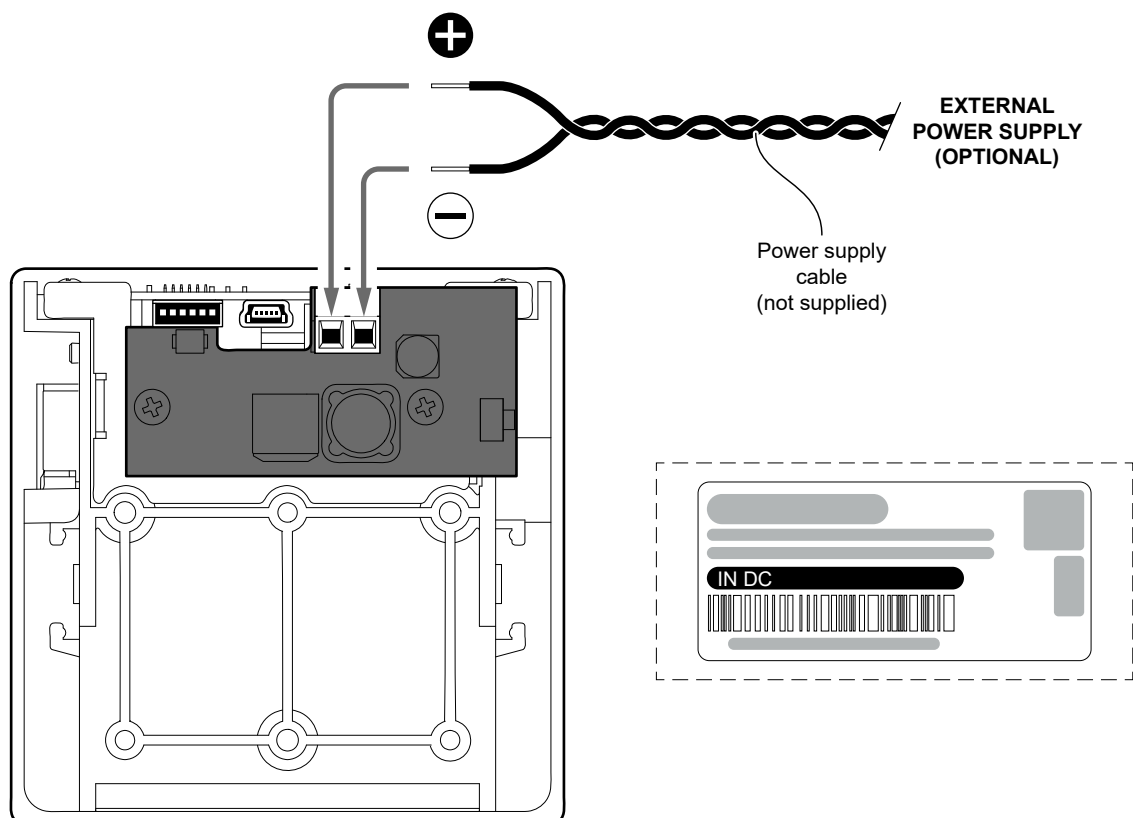

Connect the power supply cable to an external power supply unit and to the device.
Use the type of electrical power supply indicated on the label.

2

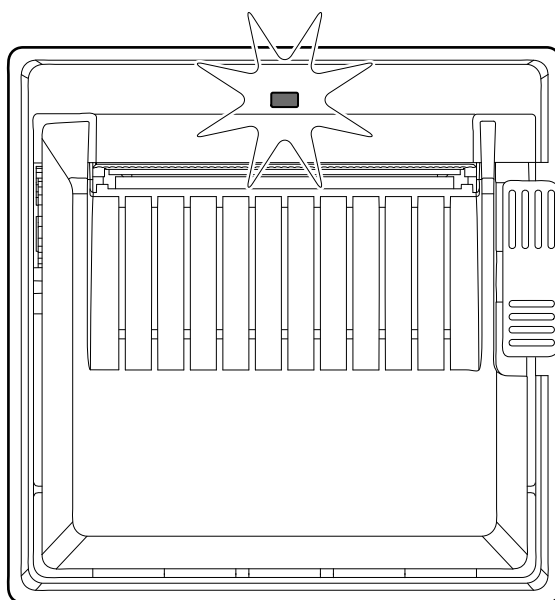

The blue status LED turns on.
The device is ready.



4.3 Loading the paper roll

To change the paper proceed as follows. At every change of paper, check inside the device to locate and remove any scraps of paper.

1

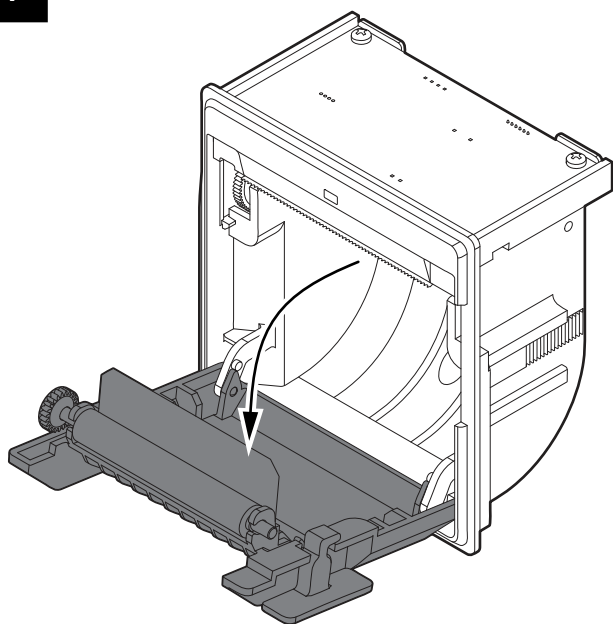

Open the cover for paper compartment
(see [paragraph 4.1](#)).

2

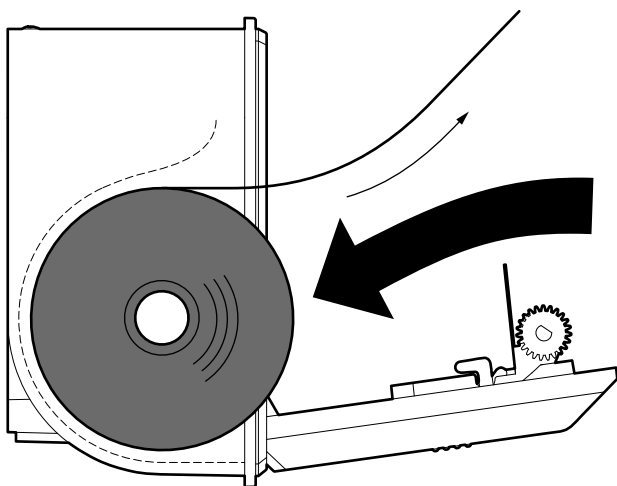

Place the roll in the paper compartment and
pull out the paper for a few centimetres.

3

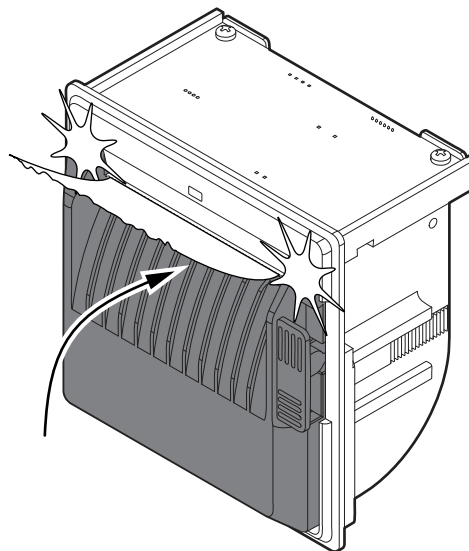

Close the cover.

4

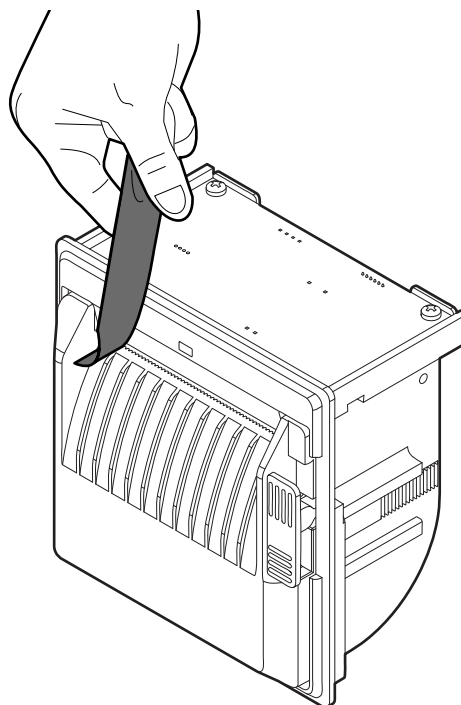

Remove the excess paper.

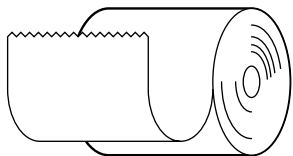
5

Thermal paper

Print Density

- √ -50%
- √ -37%
- √ -25%
- √ -12%
- √ 0
- √ +12%
- √ +25%
- √ +37%
- √ +50%

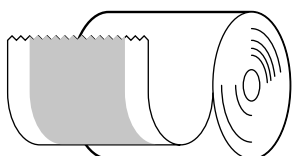

Linerless thermal paper

Print Density

- √ Linerless

When using normal thermal paper, set the parameter “Print Density” on one of the values between -50% and +50% (see [chapter 5](#)).

When using linerless thermal paper, set the parameter “Print Density” on “linerless” (see [chapter 5](#)).



5 CONFIGURATION

5.1 Configuration by software

The setup parameters can be set by using the “PrinterSet” software tool available on www.custom4u.it. For a detailed description of the device operating parameters see the following paragraphs. To configure the device by software, proceed as follows.

1

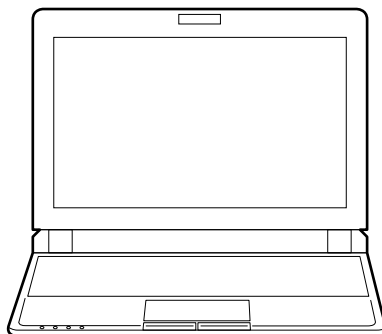

Connect the device to a PC directly (see [paragraph 3.5](#)), without using HUB devices.

2

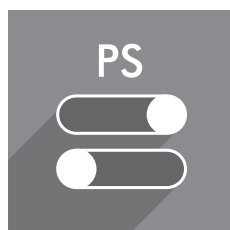

Start “PrinterSet” software tool.

3

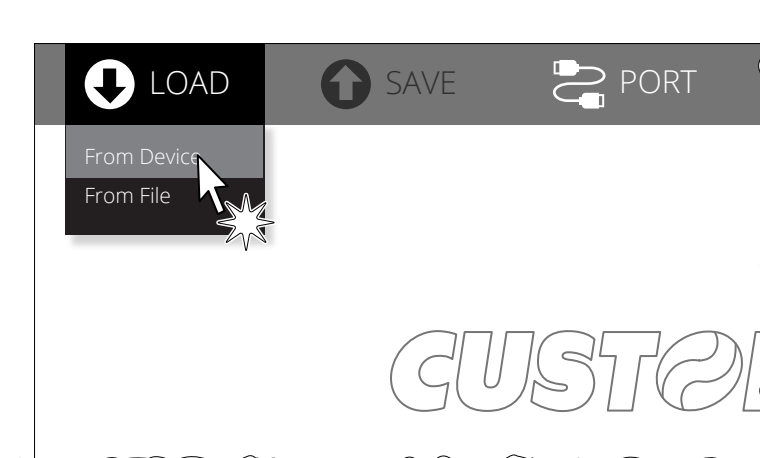

Click on LOAD > FROM DEVICE and select the device connected to the PC.

4

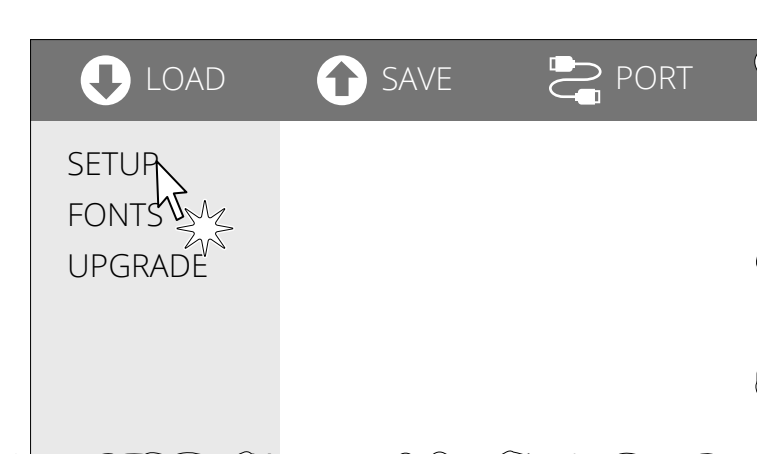

Click on SETUP to access the operating parameters of the device to be configured.

5

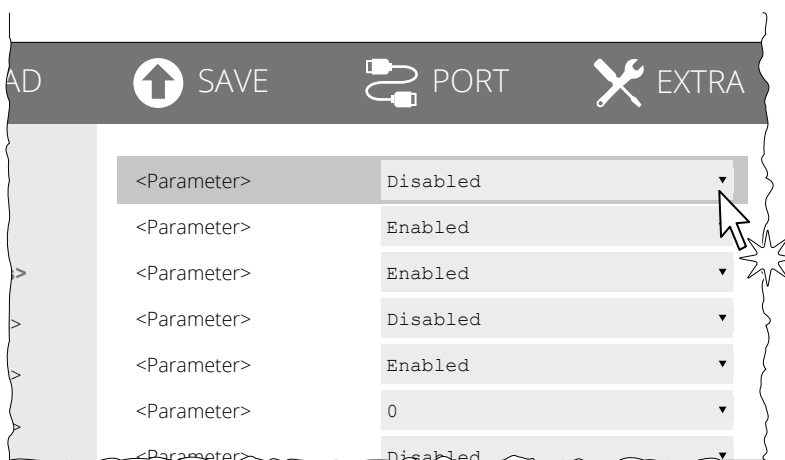

Make the desired changes to the device operating parameters.

6

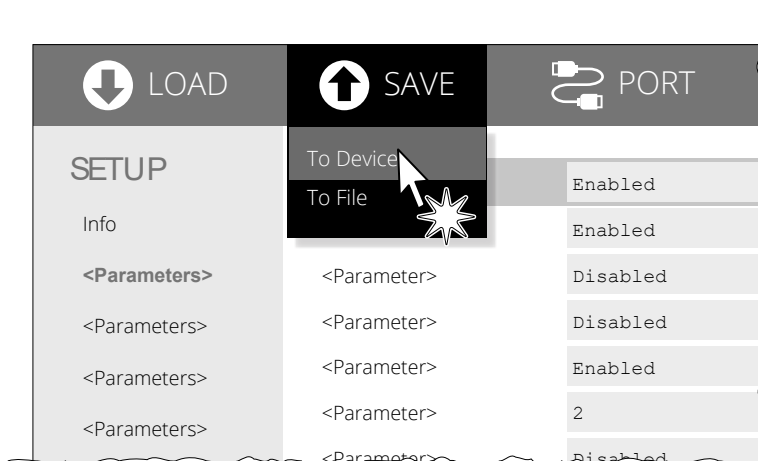

Click on SAVE > TO DEVICE to make the changes made effective.

ATTENTION:

During saving, it is strongly discouraged to disconnect the communication cable or to remove the power supply of the PC or the device.



5.2 Configuration by keys

The device is not provided with a service key.

To enter the configuration mode, you should build a service cable with a service key as described in [paragraph 3.7](#) to be connected to the serial port of the device. Then, proceed as follows.

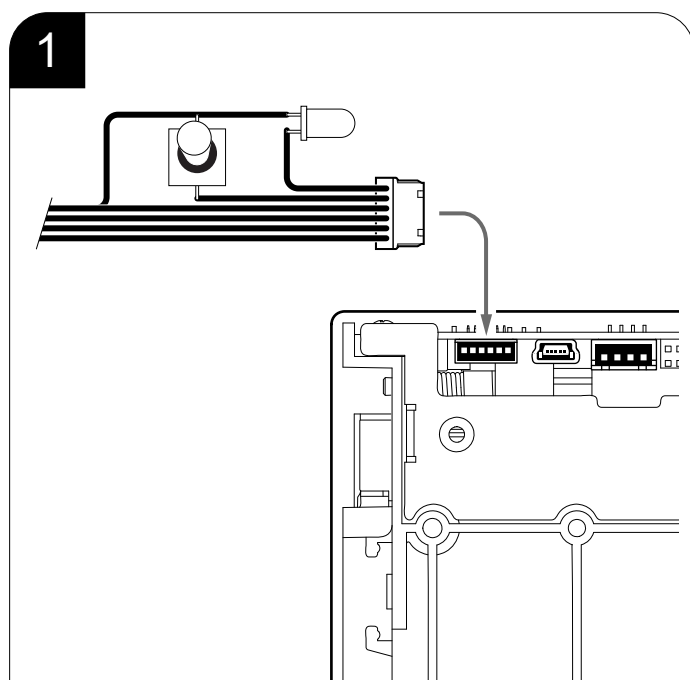

1
Connect the service cable
(see [paragraph 3.7](#)).

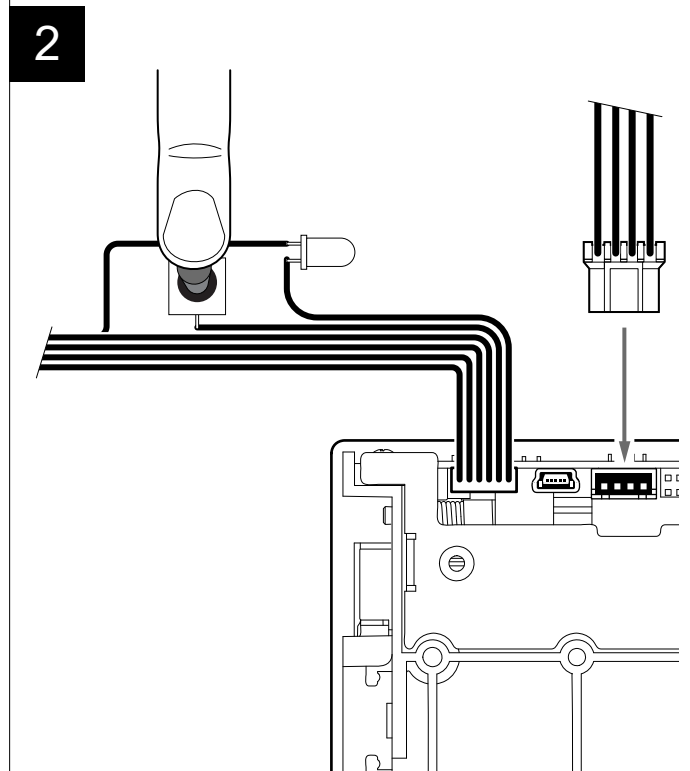

2
While pressing the service key, switch on the device by inserting the power supply cable
(see [paragraph 3.5](#)).

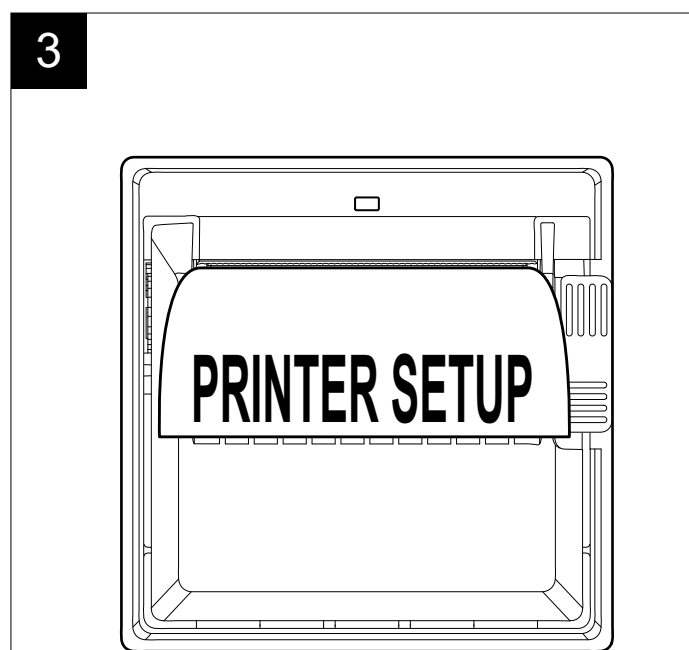

3
The device prints the report with parameters for settings.

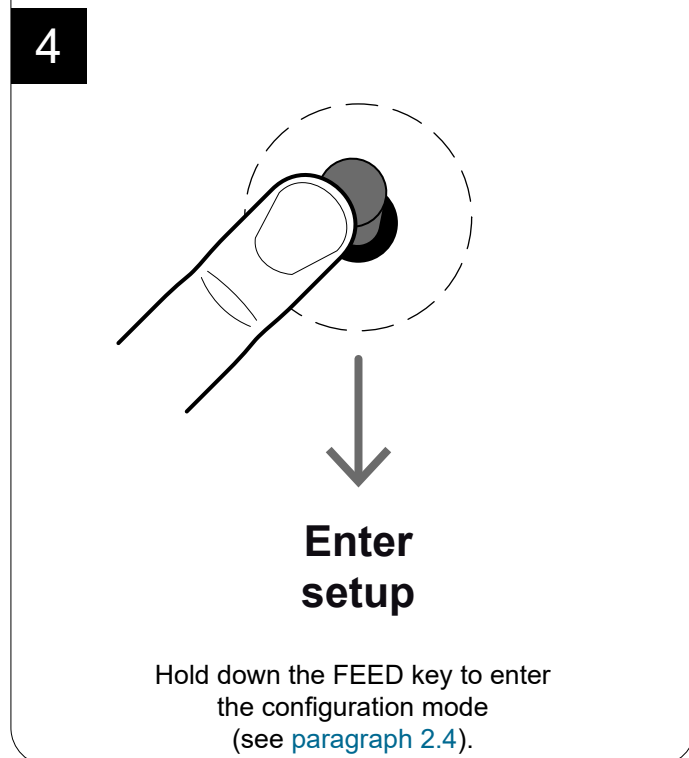

4
Hold down the FEED key to enter the configuration mode
(see [paragraph 2.4](#)).



The following figure shows the setup report of the device. The shown values for parameters are sample values; for the list and the description of device parameters see the following paragraphs.

KEYS FUNCTIONS	}	<p>[FAST PUSH] <i>to skip setup</i> [PUSH] <i>to enter setup</i></p>
DEVICE NAME AND FIRMWARE MODULES RELEASE	}	<p style="text-align: center;">< device name ></p> <p>SCODE <code> - rel 1.00 FCODE <code> - rel 1.00</p>
DEVICE STATUS	}	<p style="text-align: center;">PRINTER SETTINGS</p> <p>PRINTER TYPE<device model> PRINTING HEAD TYPE<head model> INTERFACEUSB PROGRAM MEMORY TEST.....OK DYNAMIC RAM TEST.....OK EEPROM TEST.....OK HEAD VOLTAGE [V] = 04.84 HEAD TEMPERATURE [°C] = 25 POWER ON COUNTER = 4 PAPER PRINTED [cm] = 40</p>
PARAMETERS FOR DEVICE CONFIGURATION	}	<p>Printer Emulation : PLUS RS232 Baud Rate : 9600 bps RS232 Data Length : 8 bits/chr RS232 Parity : None RS232 Handshaking : Xon/Xoff Busy Condition : RxFull USB Address Number : 0 Print Mode : Normal Autofeed : CR Enabled Chars / inch : A=13 B=17 cpi Columns 22 cpi..... : 40 columns Code Table [num] : 00 Font Type..... : International Speed / Quality..... : Normal Black Mark Position : Enabled Black Mark Threshold..... : 40% Black Mark Distance [mm]..... : 0.0 PaperEnd Buffer Clear : Disabled Power Off Command : Disabled Line Space Reduction : Disabled Line Feed Reduction : Disabled Barcode Height Reduc. : Disabled Print Density..... : 0% LED bar FGND (RRGGBB)..... : 0000FF LED bar BGND (RRGGBB)..... : 000000</p>



5.3 Device status

The device operating status is indicated in the configuration print-out in which, next to the name of the components displayed, the following information is given.

PRINTER TYPE	device model
PRINTING HEAD TYPE	print head model
INTERFACE	interface present
PROGRAM MEMORY TEST	OK appears if functioning and NOT OK if faulty
DYNAMIC RAM TEST	OK appears if functioning and NOT OK if faulty
EEPROM TEST	OK appears if functioning and NOT OK if faulty
HEAD VOLTAGE	voltage of the head
HEAD TEMPERATURE	temperature of the head
POWER ON COUNTER	number of power-ups made
PAPER PRINTED	centimetres of paper printed



5.4 Communication parameters

The device allows the configuration of the parameters listed in the following table.

The parameters marked with the symbol ^D are the default values.

Settings remain active even after the device has been turned off and they are stored in non-volatile memory.

RS232 BAUD RATE	Communication speed of the serial interface: <table border="0"> <tr> <td>1200</td> <td>9600 ^D</td> <td>57600</td> </tr> <tr> <td>2400</td> <td>19200</td> <td>115200</td> </tr> <tr> <td>4800</td> <td>38400</td> <td></td> </tr> </table> This parameter is valid only with serial interface.	1200	9600 ^D	57600	2400	19200	115200	4800	38400		
1200	9600 ^D	57600									
2400	19200	115200									
4800	38400										
RS232 DATA LENGTH	Number of bit used for characters encoding: 7 bits/car 8 bits/car ^D This parameter is valid only with serial interface.										
RS232 PARITY	Bit for the parity control of the serial interface: None ^D = parity bit omitted Even = even value for parity bit Odd = odd value for parity bit This parameter is valid only with serial interface.										
RS232 HANDSHAKING	Handshaking: XON/XOFF = software handshaking Hardware ^D = hardware handshaking (CTS/RTS) This parameter is valid only with serial interface. When the receive buffer is full, if handshaking is set to XON/XOFF, the device sends the XOFF (0x13) on the serial port. When the receive buffer has cleared once again, if handshaking is set to XON/XOFF, the device sends the XON (0x11) on the serial port.										
BUSY CONDITION	Activation mode for Busy signal: OffLine/ RXFull = Busy signal is activated when the device is both in OffLine status and the buffer is full RXFull ^D = Busy signal is activated when the buffer is full This parameter is valid only with serial interface.										
USB ADDRESS NUMBER	Numerical address code for the univocal identification of the USB device (in case of more than a USB device connected with the same PC): <table border="0"> <tr> <td>0 ^D</td> <td>2</td> <td>4</td> <td>6</td> <td>8</td> </tr> <tr> <td>1</td> <td>3</td> <td>5</td> <td>7</td> <td>9</td> </tr> </table>	0 ^D	2	4	6	8	1	3	5	7	9
0 ^D	2	4	6	8							
1	3	5	7	9							



5.5 Operating parameters

The device allows the configuration of the parameters listed in the following table.

The parameters marked with the symbol ^D are the default values.

Settings remain active even after the device has been turned off and they are stored in non-volatile memory.

PRINTER EMULATION	Available emulations for the device: CUSTOM/POS PLUS ^D FH190
PRINT MODE	Printing mode: Normal ^D = enables printing in normal writing way Reverse = enables printing rotated 180 degrees
AUTOFEED	Setting of the Carriage Return character: CR disabled ^D = Carriage Return disabled CR enabled = Carriage Return enabled
CHARS / INCH	Font selection: A = 13 cpi, B = 17 cpi ^D A = 17 cpi, B = 22 cpi A = 22 cpi, B = 17 cpi CPI = Characters Per Inch.
COLUMNS 22 cpi	Number of columns to use when the 22 cpi font is in use (see parameter “Chars / Inch”): 40 columns ^D 42 columns The parameter is printed only with PLUS or FH190 emulation enabled. To modify the parameter, set the PLUS or FH190 emulation (see parameter “Printer Emulation”) and the 17x22 cpi font (see parameter “Chars / Inch”).
CODE TABLE	Identifier number of the character code table to use. See paragraph 8.8 to learn about the character tables corresponding to the identification numbers set with this parameter. The character tables set with this parameter are the same set with the command 0x1B 0x74 (refer to the commands manual of the device).



FONT TYPE Setting of the font type:

International ^D = Enables the use of the 256 characters font tables
Chinese GB18030 = Enables the use of the chinese extended font GB18030-2000
Korean CP949 = Enables the use of the korean font CP949

When the “International” font is enabled, you need to choose the character code table (parameter “Code Table”). When the Chinese font is enabled, the selection of the character code table is suspended (parameter “Code Table”).

SPEED / QUALITY Setting of printing speed and printing quality:

High Quality
Normal ^D
High Speed
Low Current

PAPEREND BUFFER CLEAR Cleaning mode of the data in receive buffer, if the printing is stopped due to lack of paper:

Disabled ^D = the data remain in the receive buffer. When the paper runs out, the device keeps the remaining data in the receive buffer and prints the remaining portion of the ticket after that the new paper is loaded.
Enabled = when the paper runs out, all data in the receive buffer are deleted.

POWER OFF COMMAND Enables or disables Power Off command (see commands manual):

Disabled ^D = Power Off command disabled
Enabled = Power Off command enabled

LINE SPACE REDUCTION Disable or enable and adjust the reduction of the print leading:

Disabled ^D
25%
50%
75%

LINE FEED REDUCTION Disable or enable and adjust the reduction of the preset distance for paper feed (line feed):

Disabled ^D
25%
50%
75%

BARCODE HEIGHT REDUC. Enable, disable and adjust the line barcode height reduction:

Disabled ^D
25%
50%
75%



PRINT DENSITY

Adjusting the printing density:

-50% -25% 0^D +25% +50%
-37% -12% +12% +37% Linerless

The print quality is strongly influenced by the type of chemical treatment and the type of storage to which the thermal paper has been subjected, as well as by the weight of the same. It may therefore necessary to act on this parameter to obtain the desired print quality.

LED bar FGND (RRGGBB)

Set the foreground color for the status LED. This parameter consists in three value for red, green and blue color to be expressed in hexadecimal:

RR = from 00^D to FF
GG = from 00^D to FF
BB = from 00 to FF^D

LED bar BGND (RRGGBB)

Set the background color for the status LED. This parameter consists in three value for red, green and blue color to be expressed in hexadecimal:

RR = from 00^D to FF
GG = from 00^D to FF
BB = from 00^D to FF



5.6 Alignment parameters

This printer allows the configuration of the parameters listed in the following table.

The parameters marked with the symbol ^D are the default values.

Settings remain active even after the printer has been turned off and they are stored in non-volatile memory.

BLACK MARK POSITION	Management of the paper alignment:
	Disabled ^D = the black mark alignment is not performed
	Enabled = the black mark alignment is performed

BLACK MARK THRESHOLD	Threshold value (in percent) for the recognition of the presence of black mark by the black mark sensor:
	30% 50% 70% 90%
	40% ^D 60% 80%
	If the “Black Mark Position” parameter is disabled, this parameter has no effect on the device configuration and is not printed on the setup report.

BLACK MARK DISTANCE	“Black Mark Distance” is the minimum distance (in millimetres) between the upper edge of ticket and the black mark (see chapter 6). The numeric value of the distance is made up with the following four parameters for the setting of three digits (two for the integer part of the number and one for the decimal part) and of the sign:
----------------------------	--

	Sign setting:
BLACK MARK DISTANCE SIGN	+ ^D = positive distance
	- = negative distance

	Setting the digit for tens:
BLACK MARK DISTANCE [mm x 10]	0 ^D 2 4 6 8
	1 3 5 7 9

	Setting the digit for units:
BLACK MARK DISTANCE [mm x 1]	0 ^D 2 4 6 8
	1 3 5 7 9

	Setting the digit for decimals:
BLACK MARK DISTANCE [mm x 0.1]	0 ^D 2 4 6 8
	1 3 5 7 9

NOTE:
For example, to set the black mark distance to 15 mm, modify the parameters as follows:

Black Mark Distance Sign	= +
Black Mark Distance [mm x 10]	= 1
Black Mark Distance [mm x 1]	= 5
Black Mark Distance [mm x .1]	= 0



5.7 Hexadecimal dump

This function is used for the diagnosis of the characters received from the communications port. Characters are printed as hexadecimal code and the corresponding ASCII code (see below). Each line is preceded by a counter in hexadecimal that indicates the number of bytes received.

During the startup, if you hold down the FEED key, the device enters the self-test routine and print the setup report. The device remains in standby until a key is pressed or characters are received through the communication port (Hexadecimal Dump mode). For each character sent, the receipt contain an indication of the hexadecimal and ASCII values (if the characters are underlined, the receive buffer is full). Shown below is an example of a Hexadecimal Dump:

```

                                HEXADECIMAL DUMP

31 32 33 34 35 ...      12345 ...
39 30 31 32 33 ...      90123 ...
37 38 39 75 69 ...      789ui ...
68 6B 6A 73 64 ...      hkjsd ...
73 64 66 6B 6A ...      sdfkj ...
66 73 64 66 6B ...      fsdfk ...
65 69 6F 79 75 ...      eioyu ...
6F 72 69 75 77 ...      oriuw ...
6F 75 77 65 72 ...      ouwer ...
77 65 72 69 6F ...      werio ...
72 69 6F 75 77 ...      riouw ...
6B 6C 73 64 66 ...      klsdf ...
64 66 6B 73 64 ...      dfksd ...
73 64 66 6B 6A ...      sdfkj ...
66 6B F2 6A 73 ...      fk>j ...
6A 6B 6C 68              jklh
```





6 ALIGNMENT

The device is provided with a sensor that allows the use of black mark to manage:

- rolls of tickets with pre-printed fields and fixed length
- paper rolls of labels of fixed length.

The alignment black mark may be formed by:

- black mark printed on paper (see [paragraph 8.7](#))
- hole or black mark between a label and subsequent (see [paragraph 8.7](#)).

The alignment sensor assembled on the device is “reflection” sensor: this kind of sensor emits a band of light and detects the quantity of light reflected to it. The presence of the black mark is therefore detected by the amount of light that returns to the sensor, considering that the light is reflected by the white paper and absorbed by the black mark.

The following paragraphs show how to correctly set the configuration parameters of device in order to assure the alignment.



6.1 Enable alignment

Device is provided with one fixed sensor for alignment.

To guarantee proper alignment is necessary to enable the “Black Mark Position” parameter during the setup procedure (see [chapter 5](#)).

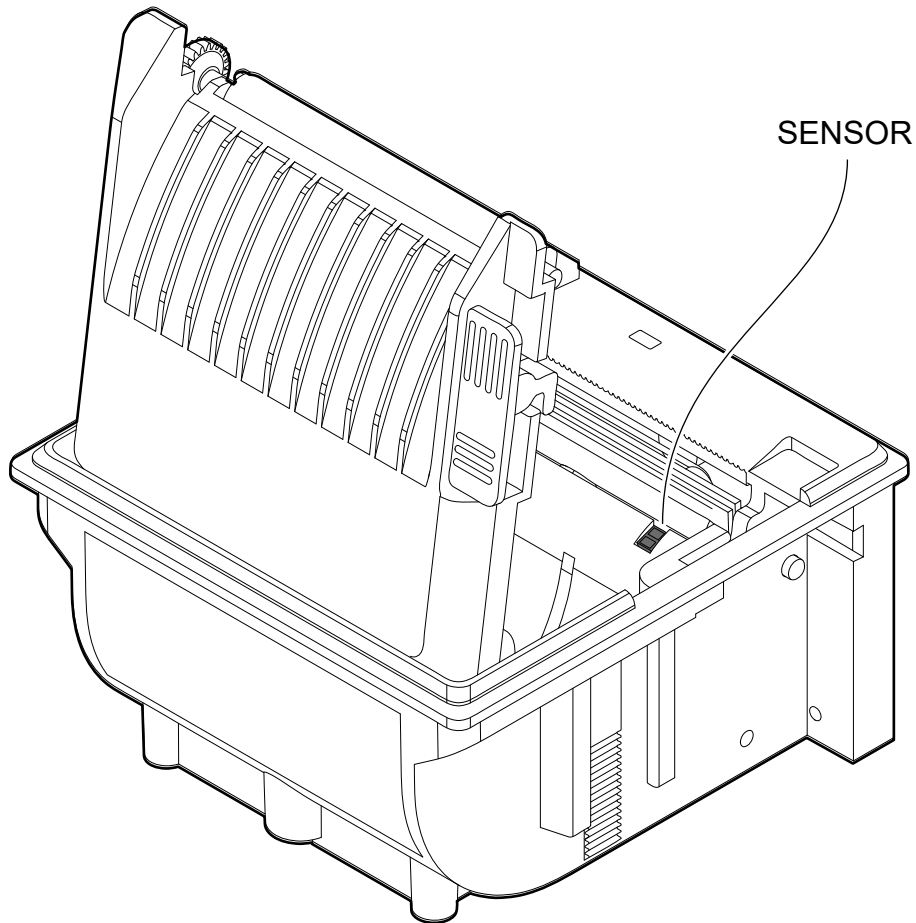



The following image shows the size of paper used and the sensor used for the alignment.

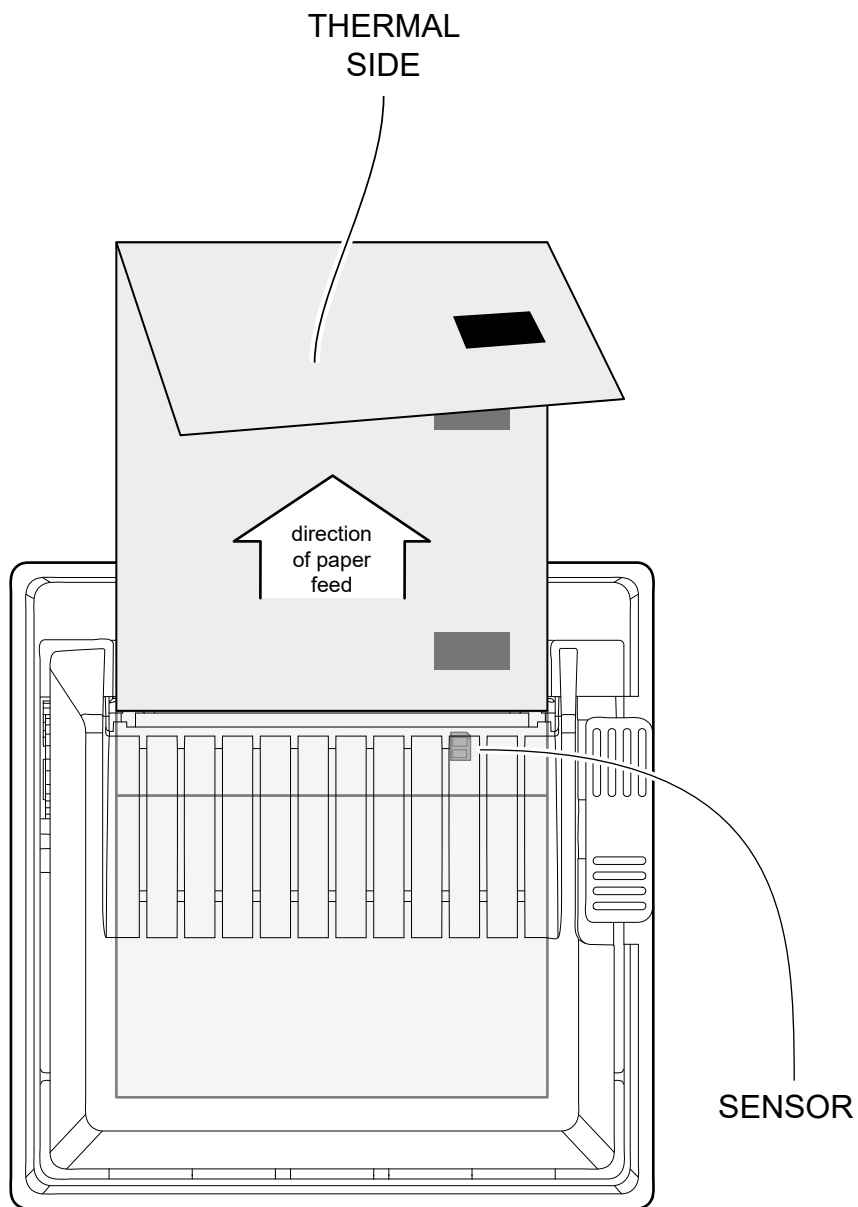

6.2 Alignment parameters

The “alignment point” is defined as the position inside the ticket to use for the black mark alignment. The distance between the black mark edge and the alignment point is defined as “Black Mark Distance”.

Referring to the front of the black mark, the value of “Black Mark Distance” value varies from -9 mm minimum and 99.9 mm maximum.

If the “Black Mark Distance” value is set to 0, the alignment point is set at the beginning of the black mark.

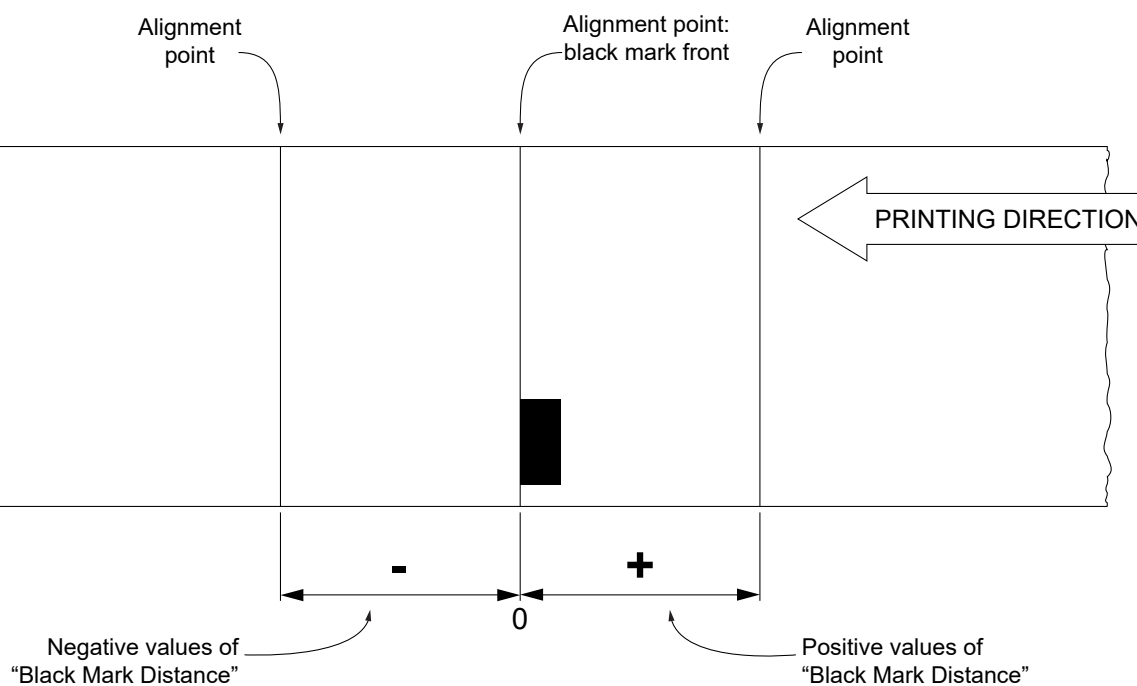



The following figure shows a simplified section of the device with the paper path and the distances (in mm) between the alignment sensor, the print head, serrated blade (cutting line).

All the dimensions shown in following figures are in millimetres.

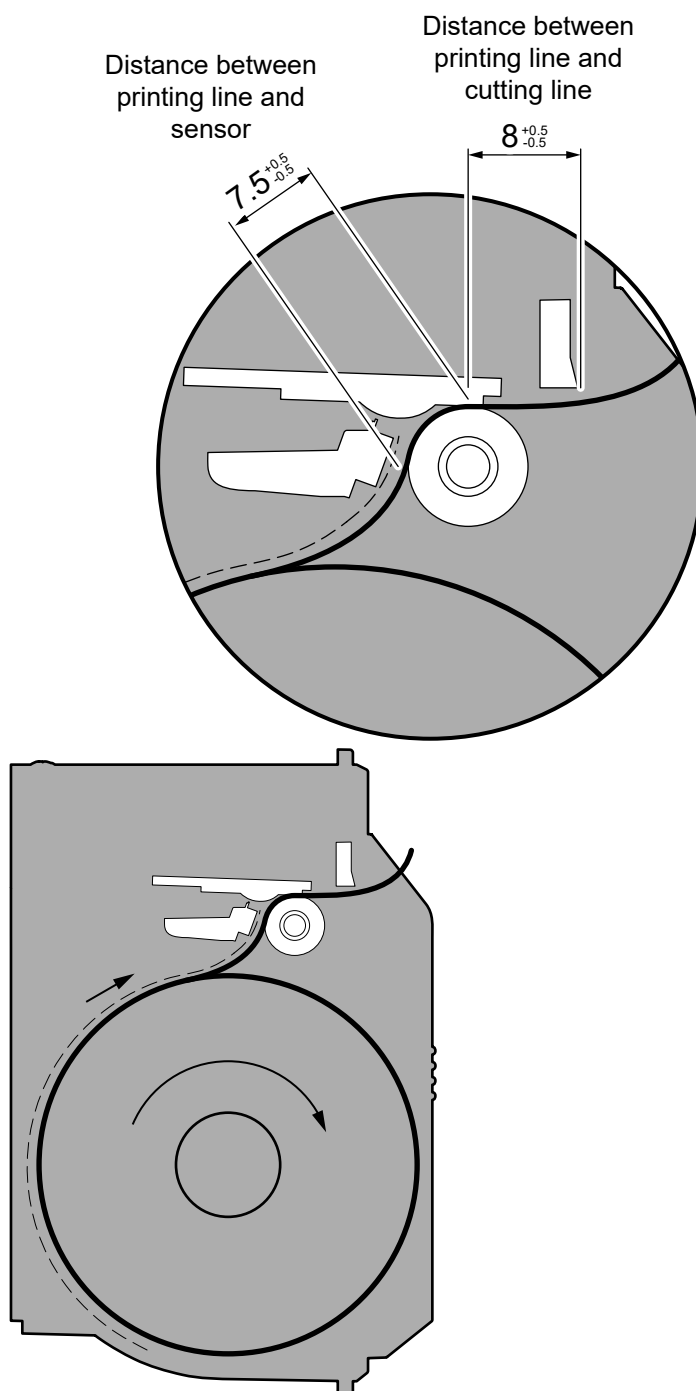

To define the alignment point you need to set the printer parameters that compose the numerical value of the “Black Mark Distance” parameter (see [paragraph 5.6](#)).

For example, to set a black mark distance of 15 mm between the black mark and the alignment point, the parameters must be set on the following values:

Black Mark Distance Sign	: +
Black Mark Distance [mm x 10]	: 1
Black Mark Distance [mm x 1]	: 5
Black Mark Distance [mm x .1]	: 0

The “Black Mark Distance” parameter, may be modified as described in [chapter 5](#).

6.3 Printing area

In order to print ticket containing only one notch and to not overlay printing to a notch (that will make it useless for the next alignment), it is important to well calibrate the length of the printing area of ticket according to the inter-notch distance.

The following figure shows an example of tickets with “Black Mark Distance” set to 0:

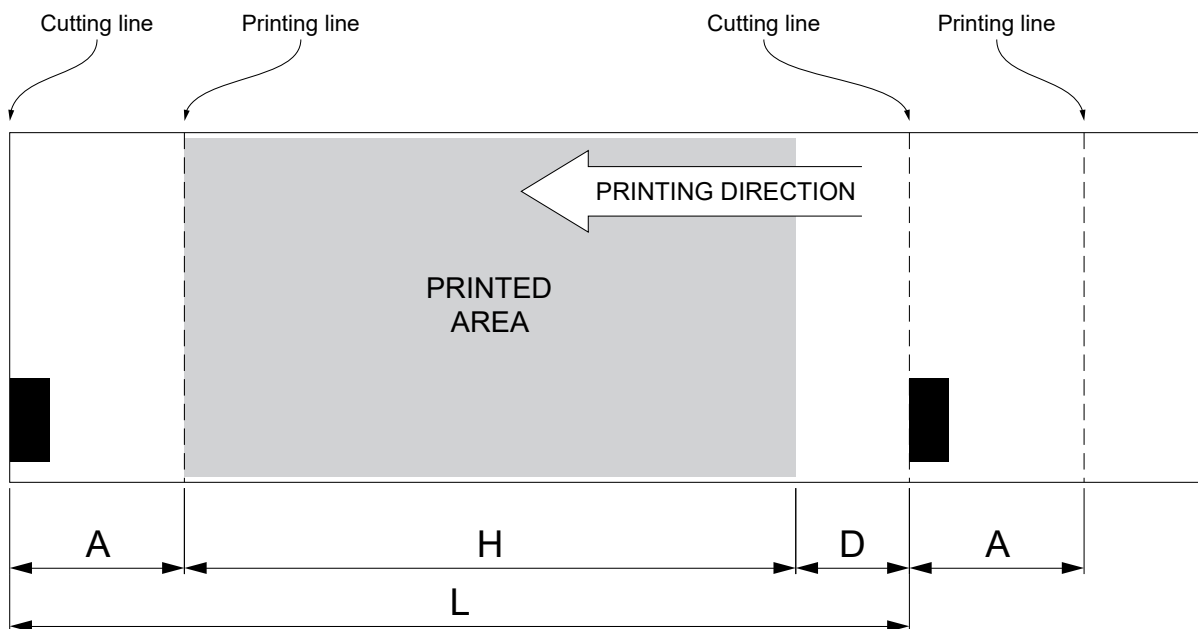

A “Non-printable area” = “Distance between cutting line/printing line”

where:

”Distance between cutting line/ printing line” = 8 mm ± 0.5 mm

H Distance between the first and the last print line, called “Height of the printing area”.

L Distance between an edge of the black mark and the next one, called “Inter-black mark distance”.

D Automatic feed for alignment at the next black mark.

To use all the notches on paper, you must comply with the following equation:

$$H + A \leq L$$

The height of the printing area (H) can be increased to make no progress on alignment (D) but no further.

7 MAINTENANCE

7.1 Paper jam

1

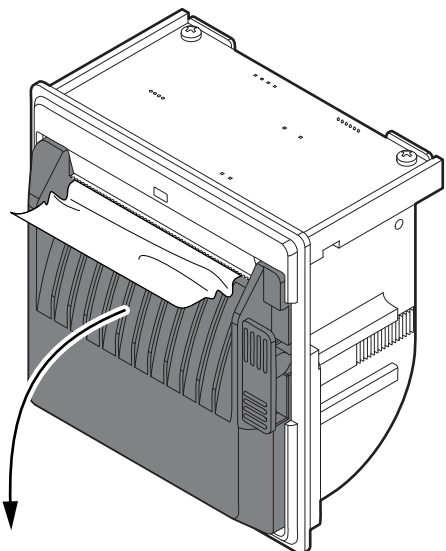

Open the cover for paper compartment (see [paragraph 4.1](#)).

2

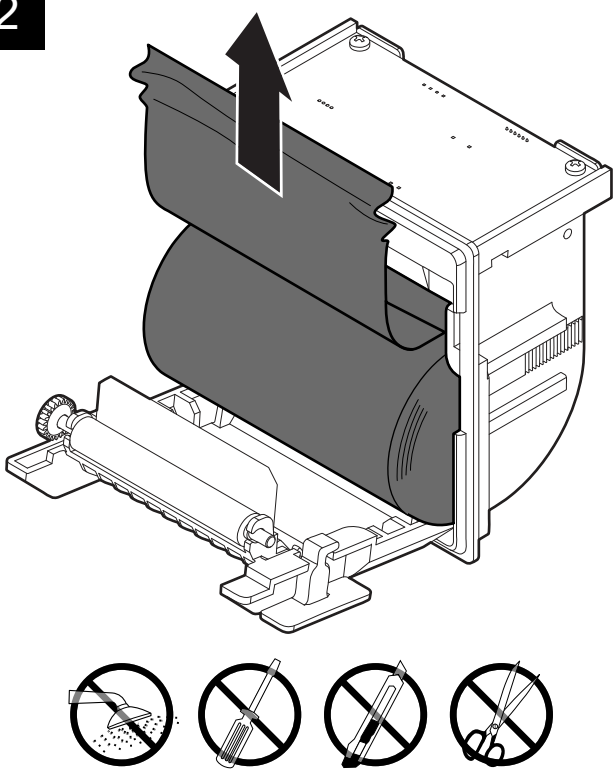

Lift the damaged paper, check and remove any scraps of paper. Pull the paper so that the damaged part remains outside the device.

3

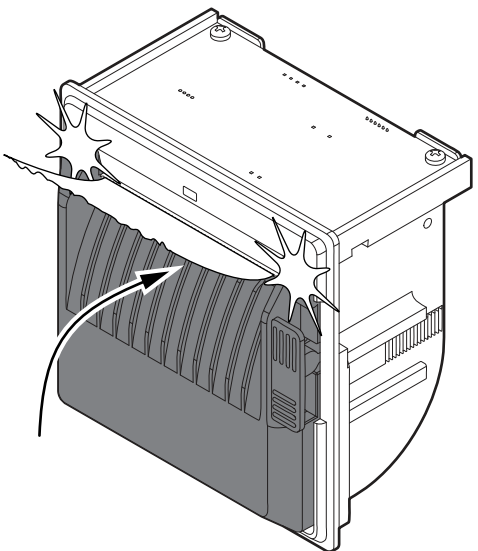

Close the cover.

4

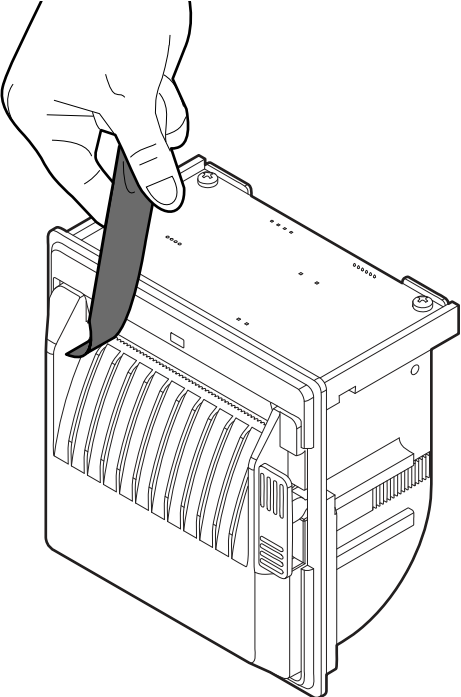

Remove the excess paper.



7.2 Planning of cleaning operations

The regular cleaning of the device keeps the print quality and extends its life. The following table shows the recommended planning for the cleaning operations. If you use the device in dusty environments, you must reduce the intervals between the cleaning operations.

For specific procedures, see the following pages.

EVERY PAPER CHANGE	
Printhead	Use isopropyl alcohol
Platen roller	Use isopropyl alcohol
EVERY 5 PAPER CHANGES	
Paper path	Use compressed air or tweezers
Sensor	Use compressed air
EVERY 6 MONTHS OR AS NEEDED	
Case	Use compressed air or a soft cloth

7.3 Cleaning

For periodic cleaning of the device, see instructions below.

Sensors

1

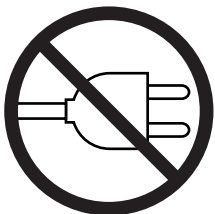



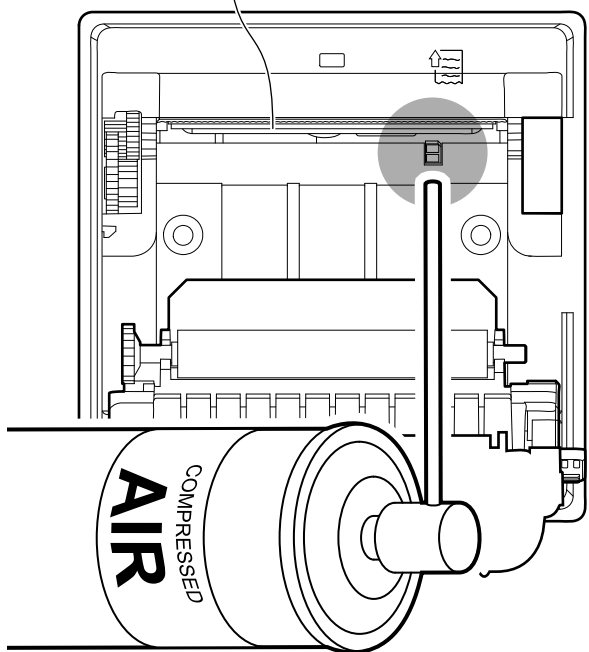

Disconnect the power supply cable and open the device cover (see paragraph 4.1).

2

ATTENTION:
Do not use alcohol, solvents, or hard brushes.
Do not let water or other liquids get inside the machine.
To remove paper scraps, use tweezers or compressed air.

Clean the device sensor by using compressed air.

Paper path

1



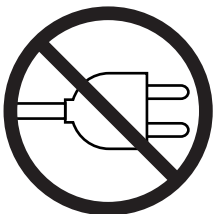

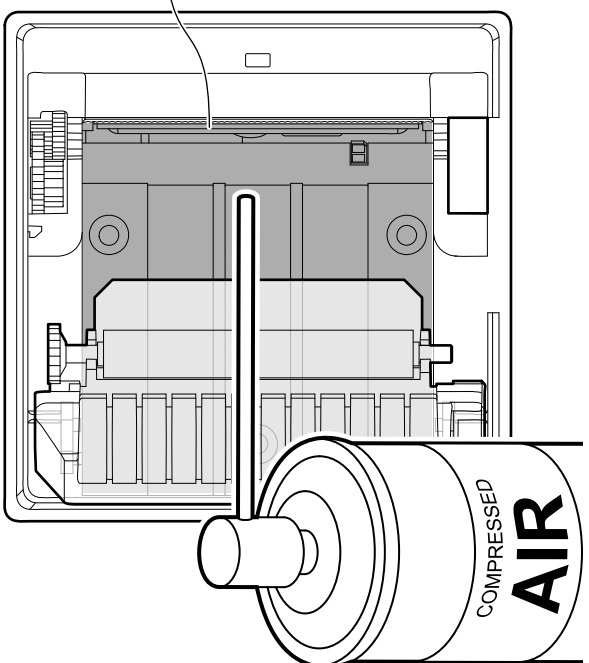

Disconnect the power supply cable and open the device cover (see paragraph 4.1).

2

ATTENTION:
Do not use alcohol, solvents, or hard brushes.
Do not let water or other liquids get inside the machine.
To remove paper scraps, use tweezers or compressed air.

Clean the area involved in the passage of paper by using compressed air.

Printhead

1

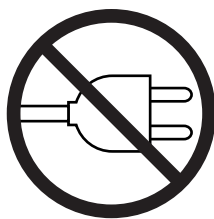

Disconnect the power supply cable and open the device cover (see [paragraph 4.1](#)).

2

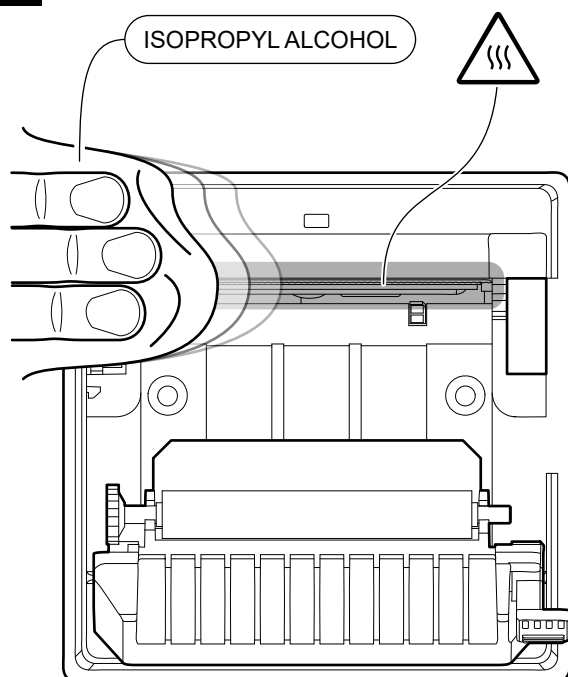

ATTENTION:

Do not use solvents, or hard brushes.
Do not let water or other liquids get inside the machine.
To remove paper scraps, use tweezers or compressed air.



Clean the printhead by using a non-abrasive cloth moistened with isopropyl.

Platen roller

1

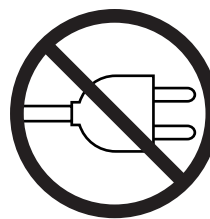

Disconnect the power supply cable and open the device cover (see [paragraph 4.1](#)).

2

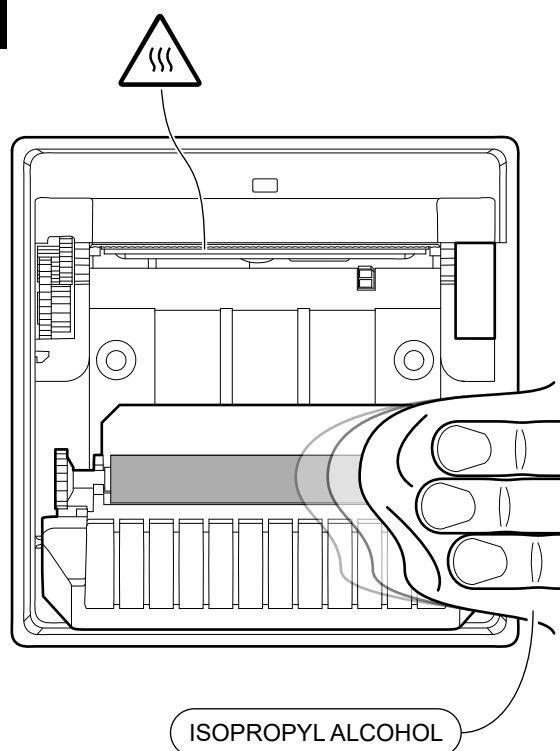

ATTENTION:

Do not use solvents, or hard brushes.
Do not let water or other liquids get inside the machine.
To remove paper scraps, use tweezers or compressed air.



Clean the platen roller by using a non-abrasive cloth moistened with isopropyl.

Case

1

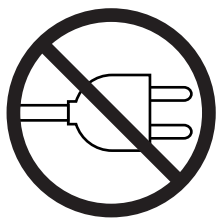

Disconnect the power supply cable.

2

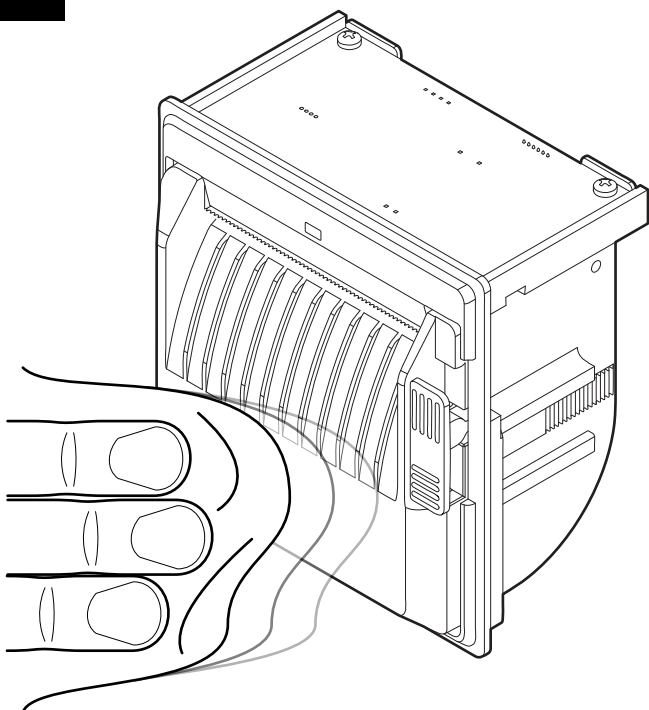

ATTENTION:

Do not use alcohol, solvents, or hard brushes.
Do not let water or other liquids get inside the machine.
To remove paper scraps, use tweezers or compressed air.



To clean the device,
use compressed air or a soft cloth.

7.4 Firmware upgrade

Firmware upgrade can be performed by using the “PrinterSet” software tool available on www.custom4u.it. To upgrade firmware, proceed as follows:

1



Login to the website www.custom4u.it, type in the product code of the device and download the latest firmware release available.

2

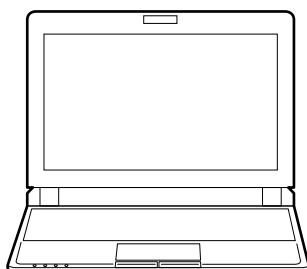

Connect the device to a PC directly (see [paragraph 3.5](#)), without using HUB devices.

3

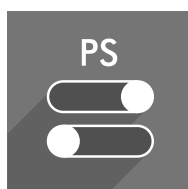

Start the “PrinterSet” software tool.

4

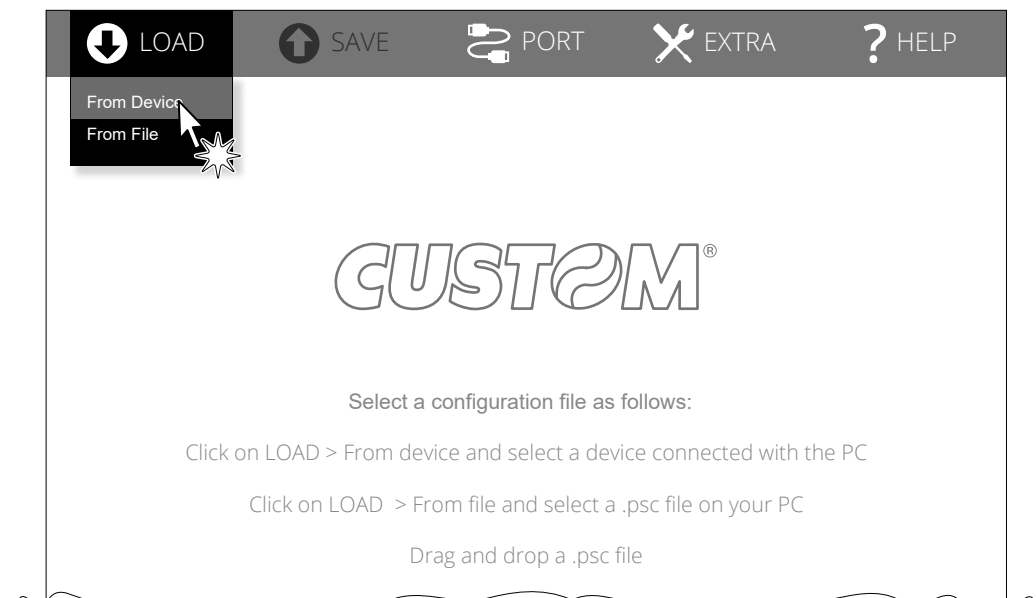

Click on LOAD > FROM DEVICE and select the device connected to the PC.

5

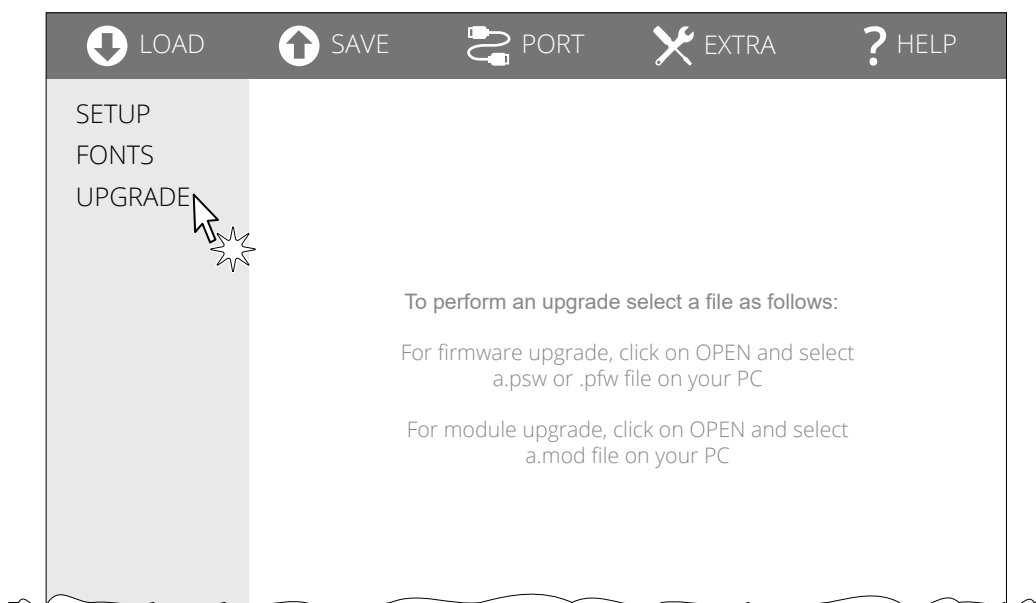

Click on UPGRADE and follow the instructions shown on the screen.

ATTENTION:

During saving, it is strongly discouraged to disconnect the communication cable or to remove the power supply of the PC or the device.





8 SPECIFICATIONS

8.1 Hardware specifications

GENERALS	
Sensors	Head temperature, paper presence, black mark alignment
Emulations	CUSTOM/POS PLUS FH190
Printing driver	Windows XP Windows VISTA (32/64bit) Windows 7 (32/64bit) Windows 8 (32/64bit) Windows 8.1 (32/64bit) Windows 10 (32/64bit) Windows 11 (32/64 bit) Self-installing driver for Virtual COM (32/64 bit) Linux (32/64 bit) Android
INTERFACES	
USB port	12 Mbit/s (USB 2.0 full speed)
RS232/TTL serial port	from 1200 bps to 115200 bps
MEMORIES	
Receive buffer	16 kB
Flash memory	8 MB (+768 kB interna)
RAM memory	256 kB
Graphic memory	Logos dynamic management (max. 32 kB graphic memory)
DEVICE	
Resolution	203 dpi (8 dot/mm)
Printing method	Thermal, fixed head



Head life ⁽¹⁾	
Abrasion resistance ⁽²⁾	100 Km (with recommended paper, 12.5% duty cycle)
Pulse durability	100 M (referred to each dot)
Printing width	48 mm
Printing mode	Normal, 90°, 180°, 270°
Printing format	Height/Width from 1 to 8, bold, reverse, underlined, italic
Character fonts	54 character code tables (see paragraph 8.8) Extended chinese GB18030-2000 Korean PC949
Printable barcode	Codabar, Code 32, Code 39, Code 93, Code 128, EAN-8, EAN-13, ITF, UPC-A, UPC-E, PDF417, QRCode
Printing speed ^{(1) (3)}	
PM2 (5 Vdc power supply)	High Speed = 54 mm/sec Normal = 42 mm/sec High Quality = 28 mm/sec Low current = 5 mm/sec
PM2 with optional module for extended range	High Speed = 60 mm/sec Normal = 45 mm/sec High Quality = 30 mm/sec
PAPER	
Type of paper	Thermal rolls, heat-sensitive side on outside of roll Linerless thermal rolls (see paragraph 8.7) Labels on roll
Paper width	57 mm ± 0.5 mm
Paper weight	from 55 g/m ² to 70 g/m ²
Paper thickness	from 63 µm to 85 µm
Recommended types of paper	KANZAN KP460 MITSUBISHI PF5067
External roll diameter	max. 50 mm
External roll core diameter	12 mm (+ 1mm)



Paper end	Not attached to roll core
-----------	---------------------------

Core type	Cardboard or plastic
-----------	----------------------

DEVICE ELECTRICAL SPECIFICATIONS

Power supply

PM2	from 4 Vdc to 8 Vdc (optional external power supply)
-----	--

PM2 with optional module for extended range	from 8 Vdc to 42 Vdc (optional external power supply)
---	---

Typical consumption ⁽³⁾	max. 3.2 A
------------------------------------	------------

Standby consumption	max. 0.070 A
---------------------	--------------

ELECTRICAL SPECIFICATIONS POWER SUPPLY code 964GE010000003 (optional)

Power supply voltage	from 90 Vac to 264 Vac
----------------------	------------------------

Frequency	from 50 Hz to 60 Hz
-----------	---------------------

Output	5 Vdc, 5 A
--------	------------

Power	25 W
-------	------

ENVIRONMENTAL CONDITIONS

Operating temperature	from -20 °C to +70 °C
-----------------------	-----------------------

Relative humidity (RH)	from 10% to 85% (without condensation)
------------------------	--

Storage temperature	from -20 °C to +70 °C
---------------------	-----------------------

Storage relative humidity (RH)	from 10% to 90% (without condensation)
--------------------------------	--

NOTES:

(1) : Respecting the regular schedule of cleaning for the device components.

(2) : Damages caused by scratches, ESD and electromigration are excluded.

(3) : Referred to a standard CUSTOM receipt (L = 10 cm, Density = 12.5% dots on).



8.2 Character specifications

Character set		3	
Character density	13 cpi	17 cpi	22 cpi
Number of columns	24	32	40/42
Chars / seconds	360	480	640
Lines / seconds	15	15	15
Characters (L x H mm) - Normal	2 x 3	1.5 x 3	1.125 x 3

NOTE: Theoretical values.

8.3 Device dimensions

Length	56.1 mm (with cover closed) 111.1 mm (with cover opened)
Height	85.5 mm
Width	85 mm
Weight	141 g

All the dimensions shown in following figure are in millimetres and referred to devices without paper roll.

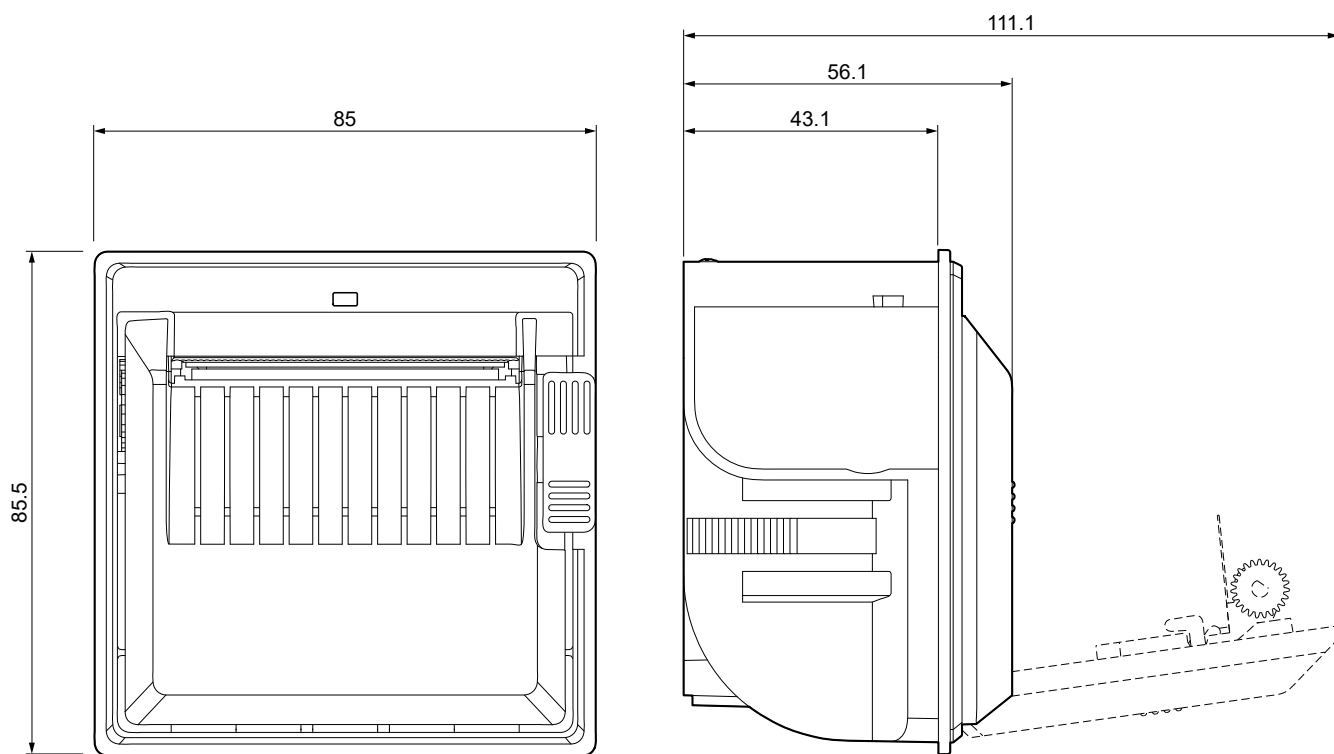



8.4 Device dimensions with extended range module code 979CW18000002 (optional)

Length	68.7 mm (with cover closed) 123.7 mm (with cover opened)
Height	85.5 mm
Width	85 mm
Weight	146 g

All the dimensions shown in following figure are in millimetres and referred to devices without paper roll.

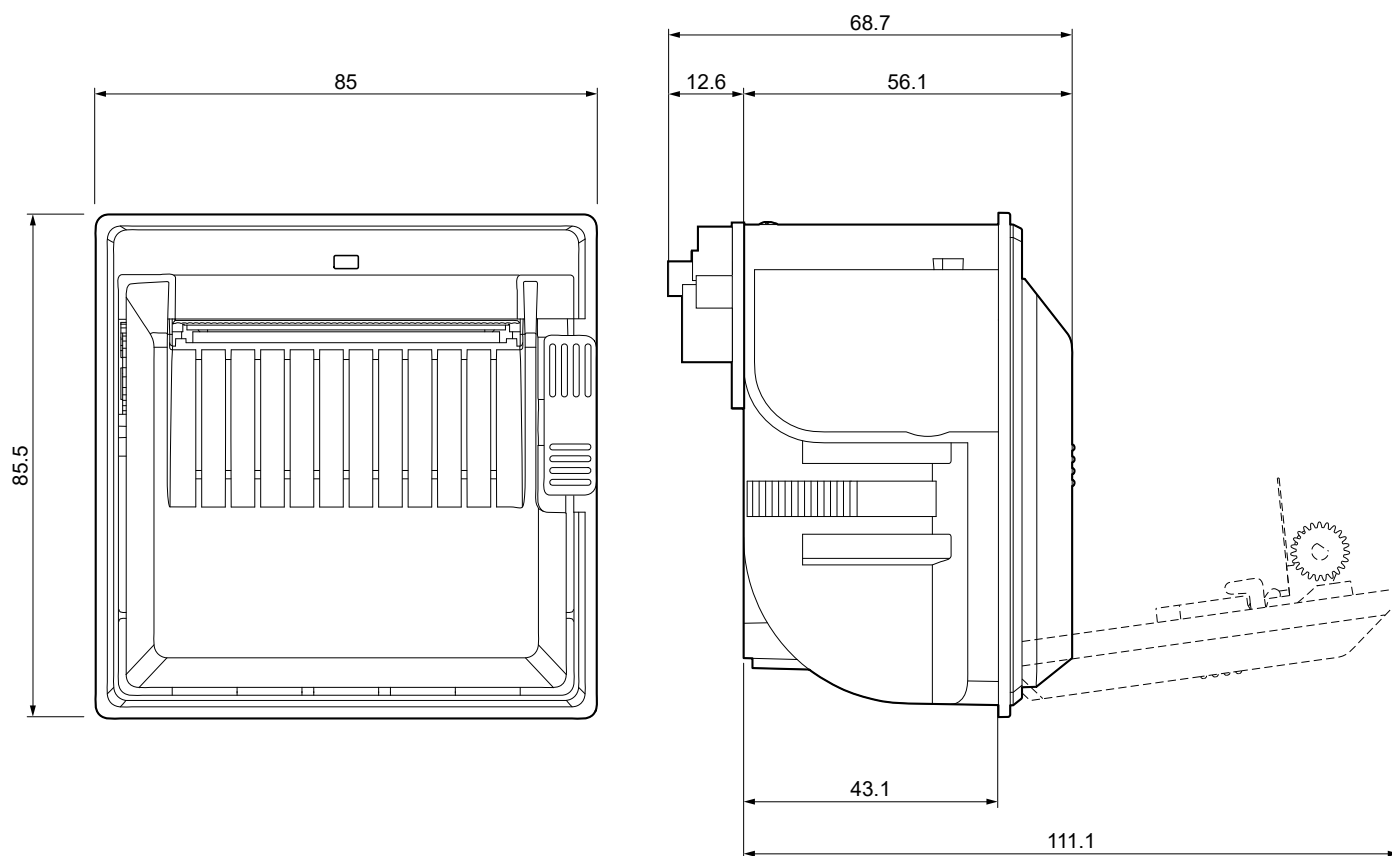



8.5 Device dimensions with grey frame 112x112 code 974CW010000315 (optional)

Length	max. 63.1 mm
Height	119 mm
Width	119 mm

All the dimensions shown in following figure are in millimetres.

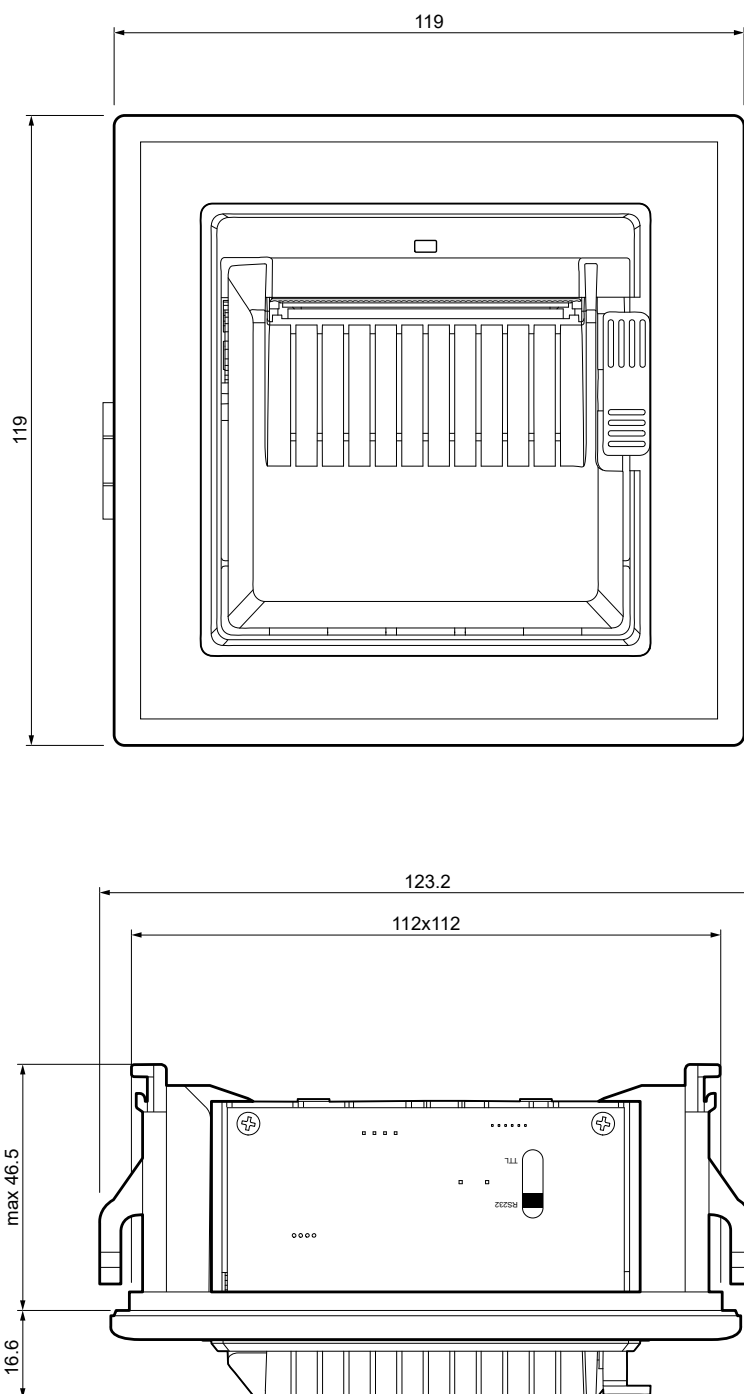



8.6 Power supply dimensions code 964GE01000003 (optional)

Length	90.6 mm
Height	28.8 mm
Width	51 mm

For the technical specifications of the power supply, see [paragraph 8.1](#).
All the dimensions shown in following figure are in millimetres.

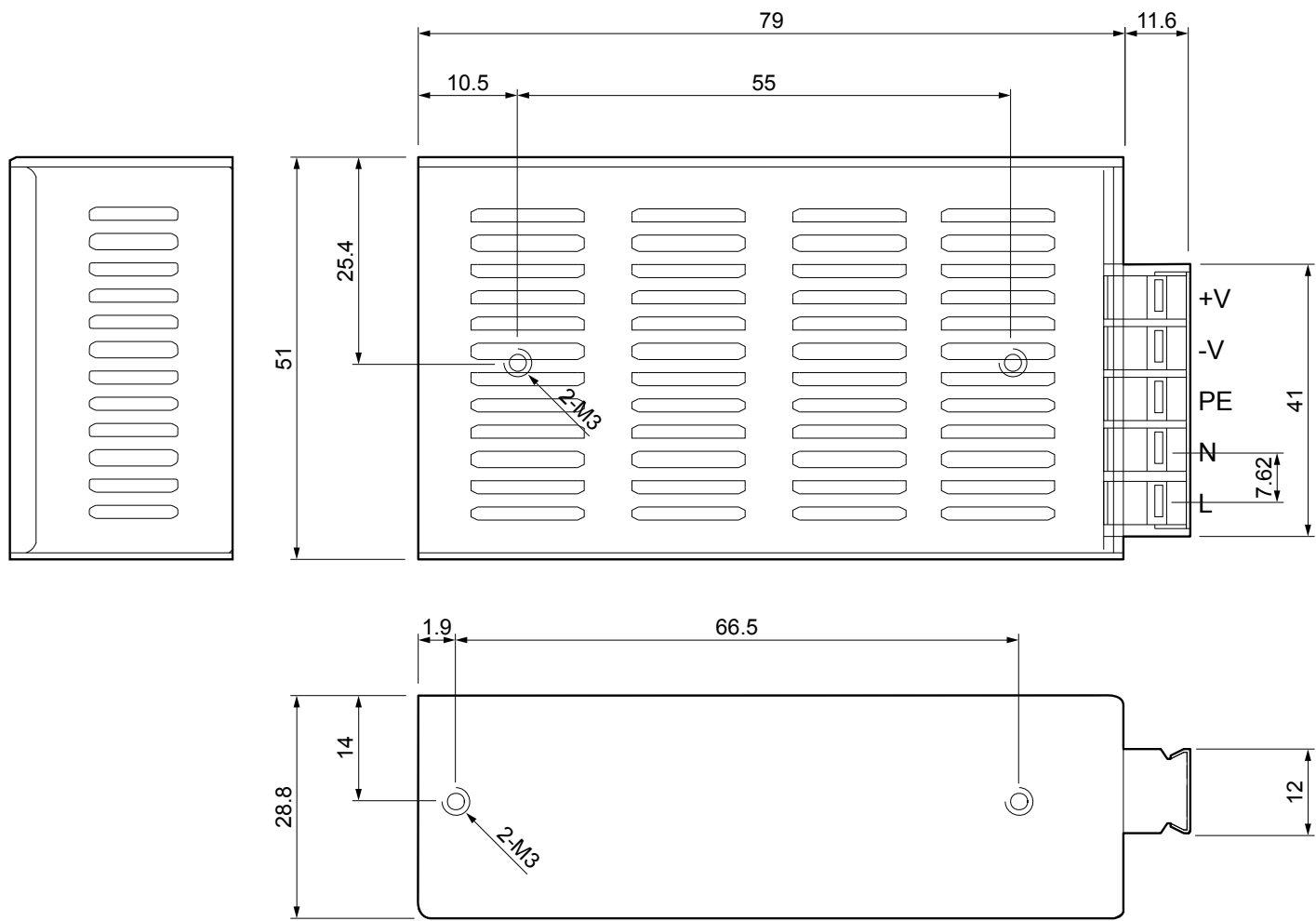

8.7 Paper specification

All the dimensions shown in following figures are in millimetres.

Paper with black mark on the thermal side

The following image shows an example of black mark placement on the thermal side of the paper. For more information about the use of paper with labels see [chapter 6](#).

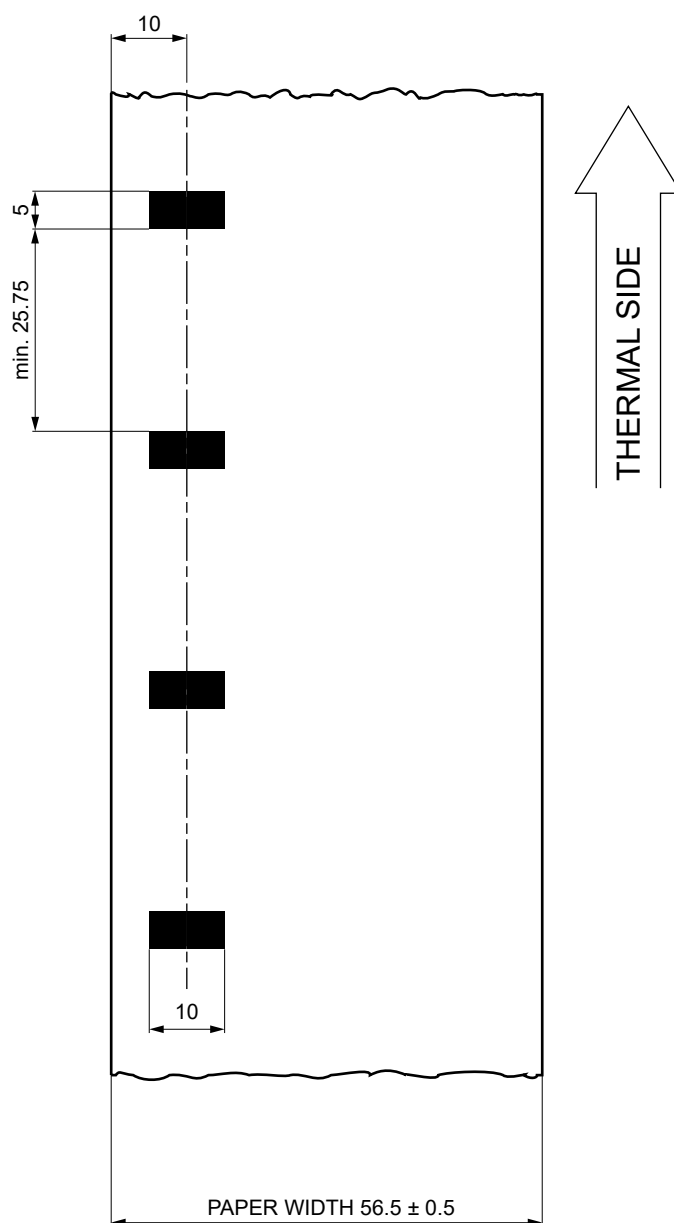

Paper with black mark and labels

The following image shows a portion of paper with labels placement of the black mark on the thermal side of the paper. To properly use the alignment commands, you need to use paper with labels that comply with the dimensions shown in the following figure.

For more information about the use of paper with labels see [chapter 6](#).

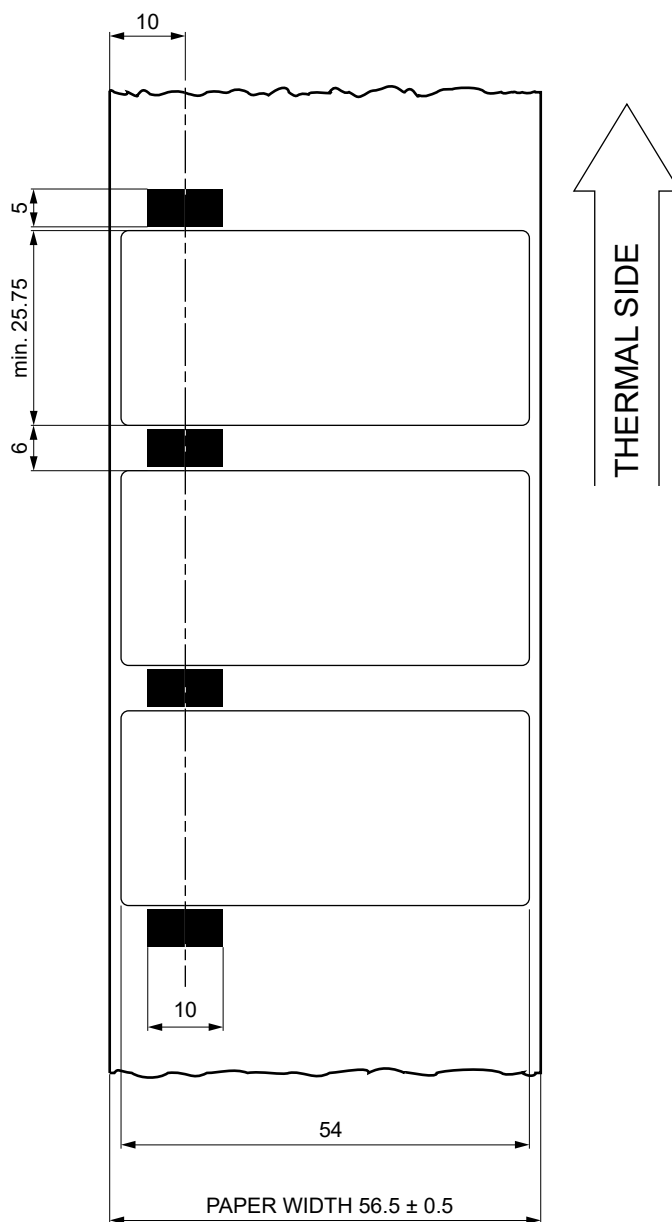

Linerless thermal paper

LINERLESS paper is a thermal paper with a self-adhesive layer without liner (on non-thermal side). For the better use with the device the self-adhesive area must comply with the following dimensions:

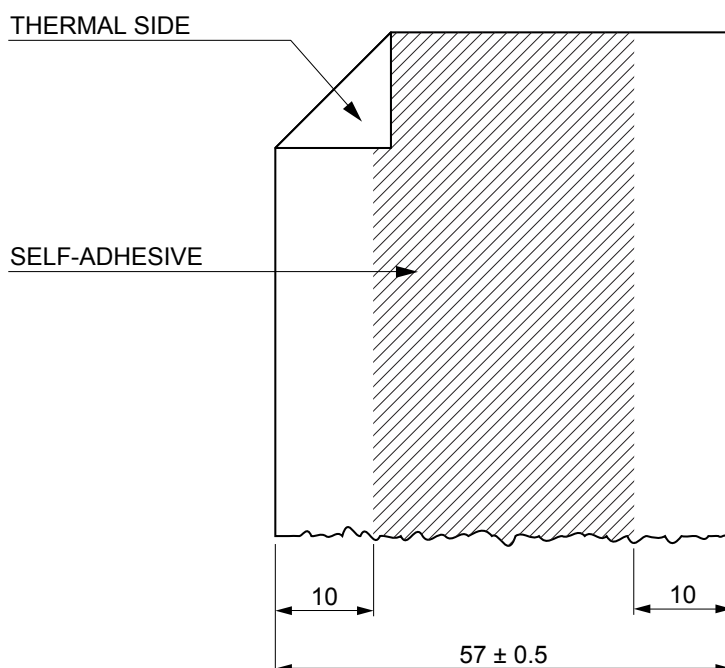

LINERLESS PAPER SPECIFICATIONS

Self-adhesive	Water based acrylic
Self-adhesive mass	Permanent $16 \text{ g/m}^2 \pm 2 \text{ g}$
Total thickness	$93 \text{ }\mu\text{m} \pm 2 \text{ }\mu\text{m}$
Total weight	$96 \text{ g/m}^2 \pm 2 \text{ g}$
Recommended temperature	
Stick	from $+15 \text{ }^\circ\text{C}$ to $+35 \text{ }^\circ\text{C}$
Storage	from $+10 \text{ }^\circ\text{C}$ to $+35 \text{ }^\circ\text{C}$
Resistance after stick	from $-10 \text{ }^\circ\text{C}$ to $+50 \text{ }^\circ\text{C}$

WARNING:

Do not set "Print Density" parameter on "Linerless" mode during the device configuration (see [chapter 5](#)) when using the device with thermal paper.

In "Linerless" mode, if the device is turned off for a few hours, the first print line may be compressed when the device is switched on. It is recommended to perform one or more paper feeds before printing.

Remove the anti-jam separator before using linerless paper (see [paragraph 3.4](#)).



8.8 Character sets

The device has 3 internal fonts with a width of 13, 17, 22 cpi, which can be associated with one of the coding tables stored on the device.

To know the coding tables actually stored on the device, print the font test (see [paragraph 2.4](#)).

The selection of the font and the encoding table is done via command (see the commands manual of the device) or through the setup procedure by properly setting the parameter “Chars / Inch”, “Code Table” and “Font Type” (see [paragraph 5.5](#)).

The following is the complete list of coding tables that can be installed on the device.

<CodeTable>	Character Tables	
0	PC437 - U.S.A., Standard Europe	
1	Katakana	
2	PC850 - Multilingual	
3	PC860 - Portuguese	
4	PC863 - Canadian/French	
5	PC865 - Nordic	
11	PC851 - Greek	on request
12	PC853 - Turkish	on request
13	PC857 - Turkish	on request
14	PC737 - Greek	on request
15	ISO8859-7 - Greek	on request
16	WPC1252	
17	PC866 - Cyrillic 2	
18	PC852 - Latin 2	on request
19	PC858 for Euro symbol at position 213	
20	KU42 - Thai	on request
21	TIS11 - Thai	on request
26	TIS18 - Thai	on request
30	TCVN_3 - Vietnamese	on request
31	TCVN_3 - Vietnamese	on request
32	PC720 - Arabic	on request
33	WPC775 - Baltic Rim	on request



<CodeTable>	Character Tables	
34	PC855 - Cyrillic	on request
35	PC861 - Icelandic	on request
36	PC862 - Hebrew	
37	PC864 - Arabic	
38	PC869 - Greek	on request
39	ISO8859-2 - Latin 2	on request
40	ISO8859-15 - Latin 9	on request
41	PC1098 - Farci	on request
42	PC1118 - Lithuanian	on request
43	PC1119 - Lithuanian	on request
44	PC1125 - Ukranian	on request
45	WPC1250 - Latin 2	
46	WPC1251 - Cyrillic	
47	WPC1253 - Greek	
48	WPC1254 - Turkish	
49	WPC1255 - Hebrew	
50	WPC1256 - Arabic	
51	WPC1257 - Baltic Rim	
52	WPC1258 - Vientamese	
53	KZ1048 - Kazakhstan	on request
255	Space page	



9 CONSUMABLES

The following table shows the list of available consumables for device.

67300000000344

THERMAL PAPER ROLL

Width = 57 mm

Ø external = 50 mm

Ø core = 12 mm

Nominal weight = 55 g/m²

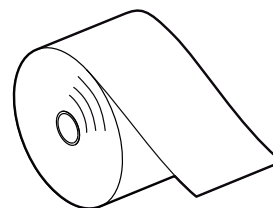



10 ACCESSORIES

The following table shows the list of available accessories for the device.

964GE01000003

POWER SUPPLY
(for technical specifications, see [paragraph 8.1](#))

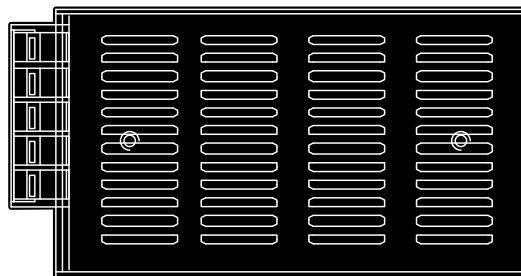

974CW010000135

GREY FRAME 112X112 (WITH CLIPS)

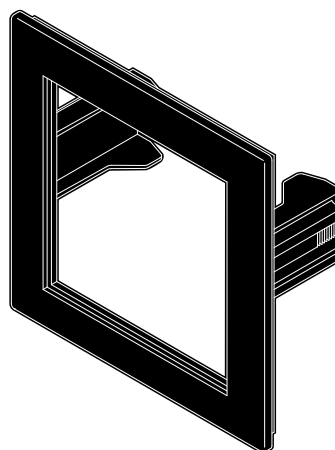

44000000032600

STARTER KIT
POWER SUPPLY CABLE + SERIAL/TTL INTERFACE 5 VOLT
Length = 500mm

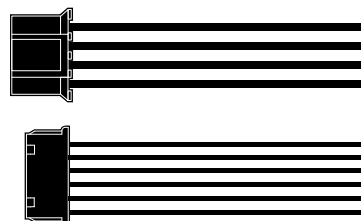

979CW180000002

EXTENDED RANGE MODULE
from 8 Vdc to 42 Vdc







11 TECHNICAL SERVICE

In case of failure, contact the technical service accessing the website www.custom4u.it and using the support tools on the homepage. It is advisable to keep the identification data of the product at hand.

The product code, the serial number and the hardware release number can be found on the product label (see [paragraph 2.3](#)). The firmware release number (SCODE) can be found:

- on the setup report (see [paragraph 5.2](#))
- connecting the device to a PC and starting the “PrinterSet” tool (see [paragraph 5.3](#))

CUSTOM[®]

CUSTOM S.p.A.

World Headquarters

Via Berettine, 2/B - 43010 Fontevivo, Parma ITALY

Tel. +39 0521 680111 - Fax +39 0521 610701

info@custom.biz - www.custom.biz

All rights reserved